

CONSTRUCTION STANDARDS

SINGLE PHASE
PRIMARY RISER

RA			
			DK

To Cutout

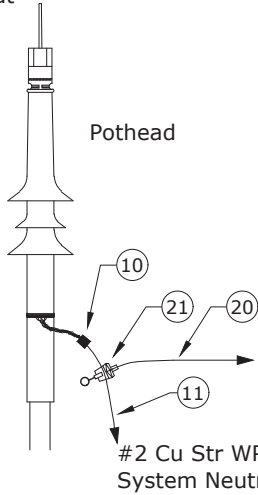

Pothead Connection Detail

Notes:

4. Connect concentric neutrals to arrester ground using #4 Cu, Red.
5. Make arrester ground terminal-to-concentric neutral jumper as short as possible.

ITEM NO.	DESCRIPTION	UA1.2	
		QTY.	Additional Material
1	Cutout, Polymer, Universal, 100A, 16kA Asym.	1	
2	Clamp, Hotline, GP 1520, #8 to 2/0 Str, Cu Only	1	
3	Screw, Lag, 1/2" x 3", Fetter Drive, Drive Point	6	
4	Bracket, Standoff Riser, 10 1/2"	3	
5	Conduit, PVC, 2" X 10', Sch 80	30	
6	End Bell, 2", Sch 40	1	
7	Terminator, 15kV, Cold-Shrink JCN & CN, #2	1	
8	Clamp, Standoff Bracket, Conduit, 2"	3	
9	Bracket, Arrester/Cutout Mounting, 1ø Fiberglass 18"	1	
10	Connector, Crimpet, Cu 2/2 - 2/2 (2C2)	1	
11	Conductor, Cu #2, 1/C, 7-Str, SD, 600V, HMP	10	
12	Bolt, Machine, 5/8" x 12", 12,400 lbs. Ultimate Tensile	1	
13	Washer, Curved, Square, Cast, 3" x 3" x 3/8" Thick x 13/16" Hole	1	
14	Washer, Lock, Spring, Double Coil, Galv. 5/8"	1	
15	Screw, Lag, 1/2" x 4 1/2", Twist Drive, Drive Point	1	
16	Washer, Flat, Round Galv., 1/2"	1	
17	Guard, Wildlife, Cutout, Polymer	1	
18	Conductor, Cu 1/C #2, 7-Str, 600V, Red, THW	3	
ITEM NO.	DESCRIPTION	LA2	
		QTY.	
19	Arrester, Surge, 9kV, MOV, Riser Pole	1	
20	Conductor, Cu 1/C #4, 7-Str, 600V, Red, THW	7	
21	Clamp, Hotline, GP 1520, #8 to 2/0 Str, Cu Only	2	
22	Connector, Compression Lug, #4, Cu/Al, One-Hole, Tin-Plated, For Arrester	2	
23	Guard, Wildlife, Polymer Arrester	1	
ITEM NO.	DESCRIPTION	N1	
		QTY.	
24	Rod, Ground, 5/8" x 8'	1	
25	Clamp, Ground Rod, 5/8", Bronze Small	1	
26	Conductor, Copper-Clad Steel, #4 Cu Equivalent, Covered	40	
27	Connector, Cabelok, Al/Cu, #2-2/0 Run, #6-#1 Tap	1	
28	Staple, Ground, Barbed, Galv. 1 1/2"	24	

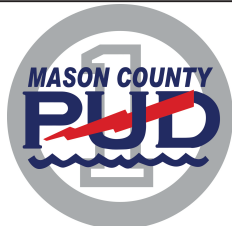

CONSTRUCTION STANDARDS

SINGLE PHASE
PRIMARY RISER

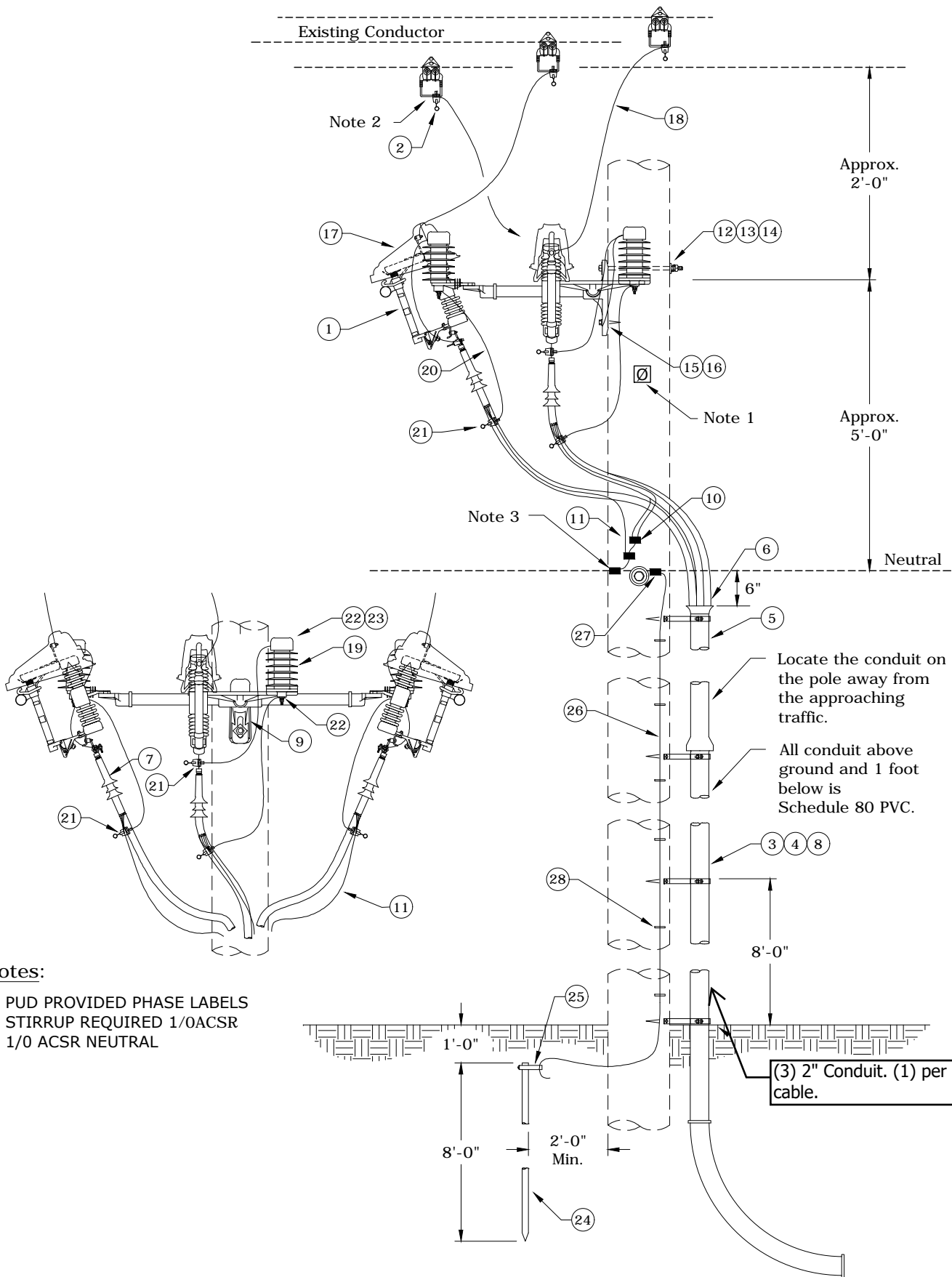

Notes:

- 1. PUD PROVIDED PHASE LABELS
- 2. STIRRUP REQUIRED 1/0ACSR
- 3. 1/0 ACSR NEUTRAL



CONSTRUCTION STANDARDS

THREE PHASE
PRIMARY RISER

△			

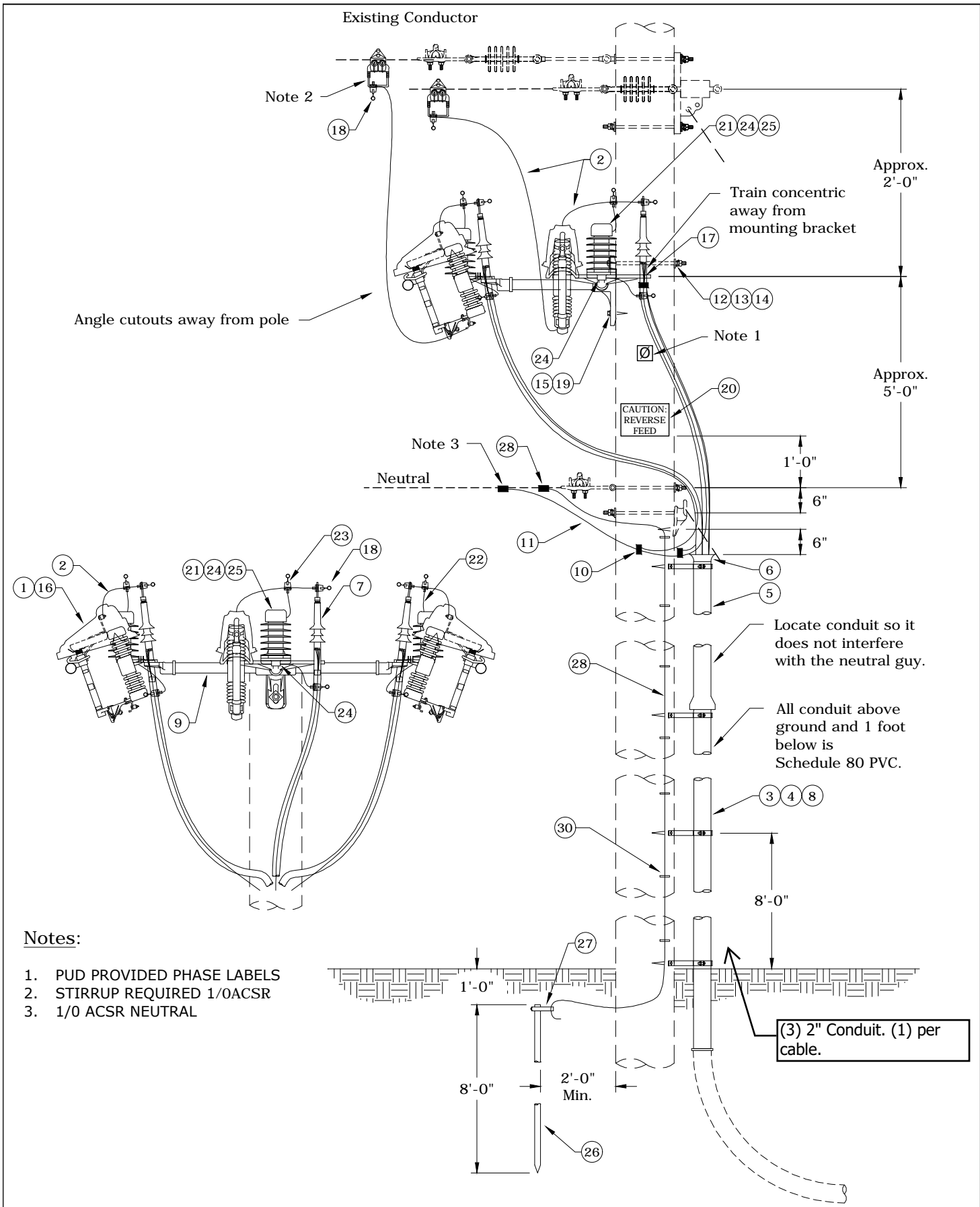

Notes:

- 1. PUD PROVIDED PHASE LABELS
- 2. STIRRUP REQUIRED 1/0ACSR
- 3. 1/0 ACSR NEUTRAL

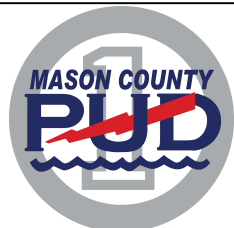

CONSTRUCTION STANDARDS

THREE PHASE
PRIMARY RISER
REVERSE FEED

△			

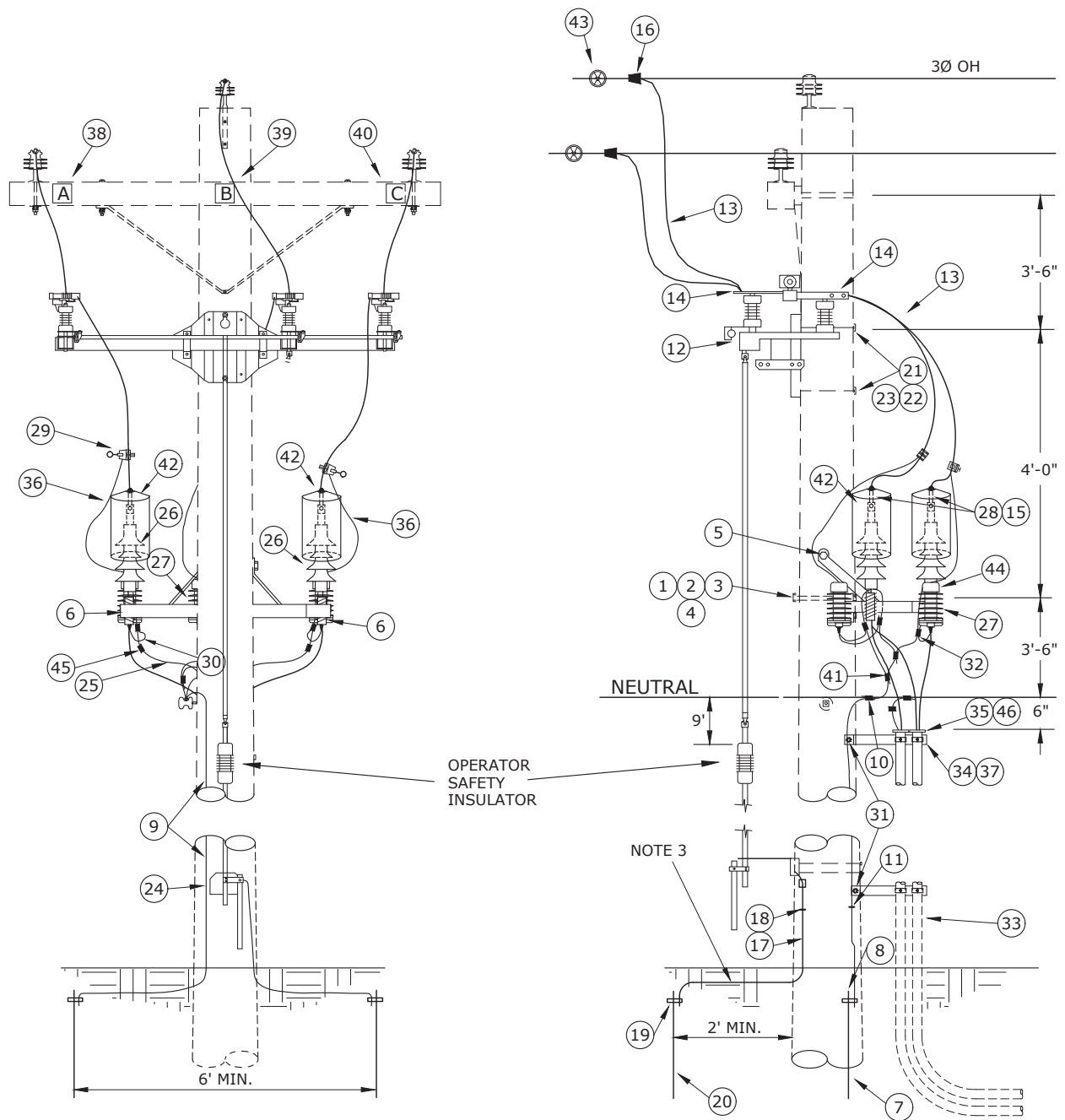

OPERATOR
SAFETY
INSULATOR

NOTE 3

Notes:

1. See HC3.3 for grounding details.
2. All ground wire is #4 Cu equivalent covered copper-clad steel.
3. Avoid sharp turns in lightning arrester grounds and primary leads.
4. The pole must be 45' Class 2 or taller.

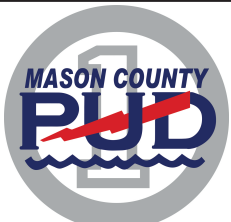

CONSTRUCTION STANDARDS

500MCM CABLE RISER
WITH 3Ø SWITCH

⚠			

ITEM NO.	DESCRIPTION	UC3.3GOS	
		BR10	
		QTY.	
1	Bracket, Terminator, Mount, 48", 500MCM	1	
2	Bolt, Machine, 5/8" x 14", Galv, 12,400 lb Ultimate Tensile	1	
3	Washer, Curved, Square, Cast, 3" x 3" x 3/8" Thick x 13/16" Hole, Galv	1	
4	Washer, Lock, Spring, Double Coil, Galv 5/8"	1	
5	Screw, Lag, 1/2" x 4 1/2", Twist Drive, Drive Point	3	
6	Support, Cable, 500MCM	3	

ITEM NO.	DESCRIPTION	N1	
		QTY.	
7	Rod, Ground, 5/8" x 8'	1	
8	Clamp, Ground Rod, 5/8", Small, Bronze	1	
9	Conductor, Copper-Clad Steel, #4 Cu Equivalent, 40% Annealed, Black Jacket with Green Stripe	40*	
10	Connector, H-Tap, Al/Cu, Run #2 - 2/0 Str, Tap #6 - #1 Str	1	
11	Staple, Ground Wire, Barbed, Galvanized, 1 1/2"	24	

ITEM NO.	DESCRIPTION	ADDITIONAL MATERIAL	
		QTY.	
12	Switch, Loadbreak, Horizontal, 600A, 15kV	1	
13	Conductor, OH, ACSR, 336, Merlin	60	
14	Connector, Compression, Lug, 2-Hole, 336 ACSR	6	
15	Bolt, 1/2" x 2", w/ Flat and Belleville Washers, Assembly	6 *	
16	Connector, Tap, Wedge, Run and Tap 336 ACSR	3	
17	Conductor, Copper-Clad Steel, #4 Cu Equivalent, 40% Annealed, Black Jacket with Green Stripe	20	
18	Staple, Ground Wire, Barbed, Galvanized, 1 1/2"	5	
19	Clamp, Ground Rod, 5/8", Small, Bronze	1	
20	Rod, Ground, 5/8" x 8'	1	
21	Machine Bolt, 3/4" x 16" Galv., 18,350 lbs. Ultimate Tensile	2	
22	Washer, Curved, Cast, 4" x 4" with 13/16" Hole	2	
23	Washer, Lock Spring, Double Coil, Galv. 3/4"	2	
24	Lock, Padlock, 2" Hardened Stainless Steel Shackle	1	
25	Conductor, OH, 600v, Cu, 2/0, 19-Str, XLPE, 80 mil, Soft-Drawn, 1C, RHW-2	60	
26	Terminator, 15kV, Cold-Shrink JCN, 500 MCM	3	
27	Arrester, Surge, 9kV, MOV, Riser Pole	3	
28	Connector, Compression, Lug, Al/Cu, Tin-Plated, 500MCM to NEMA 2-Hole	3	
29	Clamp, Hot Line, GP 1530, Line #6 Sol - 400MCM, Tap #6 Sol - 4/0 Str Cu Only	3	
30	Conductor, OH, Cu, #4 Solid, Bare, Soft-Drawn, 1C	10	
31	Screw, Lag, 1/2" x 4 1/2", Twist Drive, Drive Point	9	
32	Connector, Crimpet, Cu, Run 3/0 - 4/0 Str, Tap #6 Sol - #2 Str	3*	
33	Conduit, 3" x 10', Sch 80	90*	
34	Clamp, Standoff Bracket, 3"	9	
35	End Bell, 3" Sch 40	3	
36	Conductor, OH, 600v, Cu, #2, 7-Str, XLPE, 60 mil, Soft-Drawn, 1C, RHW-2	15	
37	Bracket, Standoff, 15" with Stop and Brace	3	
38	Tag, Phase A	1	
39	Tag, Phase B	1	
40	Tag, Phase C	1	
41	Connector, Crimpet, Cu, Run and Tap 1/0 - 2/0 Str	2 *	
42	Guard, Wildlife, Large, OH/UG Terminators	3	
43	Indicator, Fault, 400A, OH, Beacon with Signal Flag, Electric Field Reset	3	
44	Guard, Wildlife, Polymer Arrester	3	
45	Connector, Crimpet, Cu, Run 3/0 Str - 250 Str, Tap #6 Sol - 2/0 Str	3	
46	Grip, Support, 3" Conduit, 500MCM	3	



CONSTRUCTION STANDARDS

500MCM CABLE RISER
WITH 3Ø SWITCH

△R			

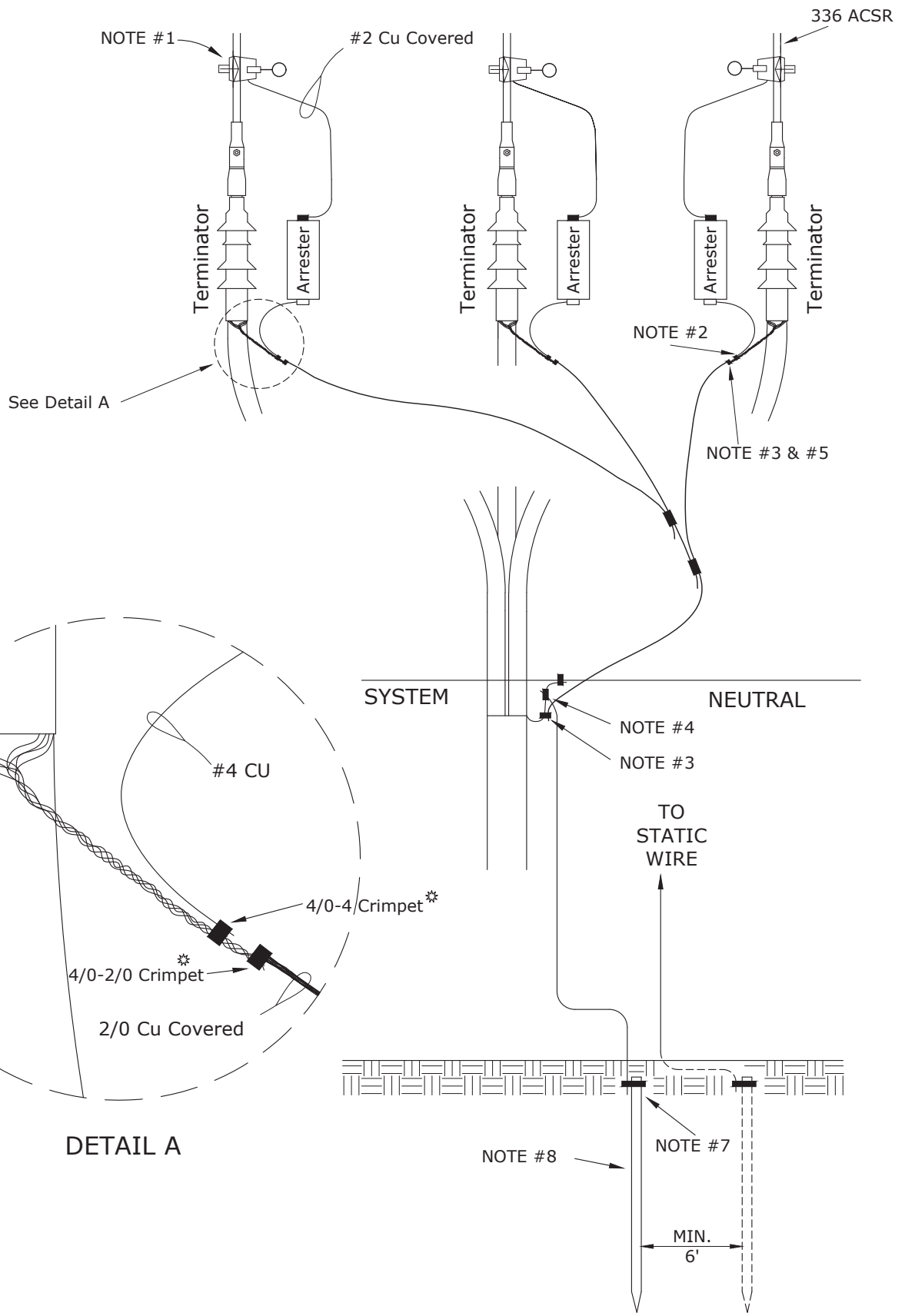

CONSTRUCTION STANDARDS
 500 MCM CABLE RISER
 GROUNDING DETAIL

R				

NOTES:

1. Make connections as close to terminator as possible but DO NOT make a sharp bend. Use hot line clamp for easy removal.
2. Connect surge arrester lead to concentric neutral.
3. Connect concentric neutral wires (twist together) to 2/0 stranded copper with 4/0-2/0 crimpet. Connect separate 2/0 runs, as per drawing, from each concentric neutral to the system neutral. Use 2/0 covered conductor and train this conductor back down along the 500MCM cable for appearance.
4. Use separate ground lead for system neutral grounding connection. Any other equipment grounds may be connected to this ground lead also per NESC 092B3.
5. Do not connect arrester grounds separately to system neutral. Connect to concentric neutral as near to the terminator as possible per NESC 097B.
6. Do not ground equipment mounting bracket per NESC 123A.
7. Top of ground rod must be buried per NESC 094C2a3.
8. If more than one ground rod is required they must be separated by at least 6 feet per NESC 094C2a2.



CONSTRUCTION STANDARDS

500 MCM CABLE RISER
GROUNDING DETAIL

⚠			

--	--

ITEM NO.	DESCRIPTION	UK3.2	
		QTY.	
1	End Bell, 3", Sch. 40	2	
2	Bracket, Standoff Riser 10-1/2" U.G.	3	
3	Clamp, Standoff Bracket, 3"	3	
4	Screw, Lag 1/2" X 3"	6	
5	Connectors - As Reqd	3	
6	Conduit, PVC, Sch 80, 3" x 10'	30*	
7	Pedestal, Secondary, Aboveground W/ Connectors and Covers	1	
	Elbow, PVC, 3", 90°, 24" Radius, Sch. 40 Straight	1	
	Elbow, PVC, 3", 90°, 36" Radius, Sch. 40	1	



CONSTRUCTION STANDARDS

SECONDARY OVERHEAD TO
UNDERGROUND RISER ASSEMBLY
W/ SECONDARY PEDESTAL

△			
△			

LEGEND:

○ Fault indicator

└ Source

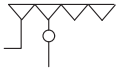

Note:
Source and load
is always left to right.

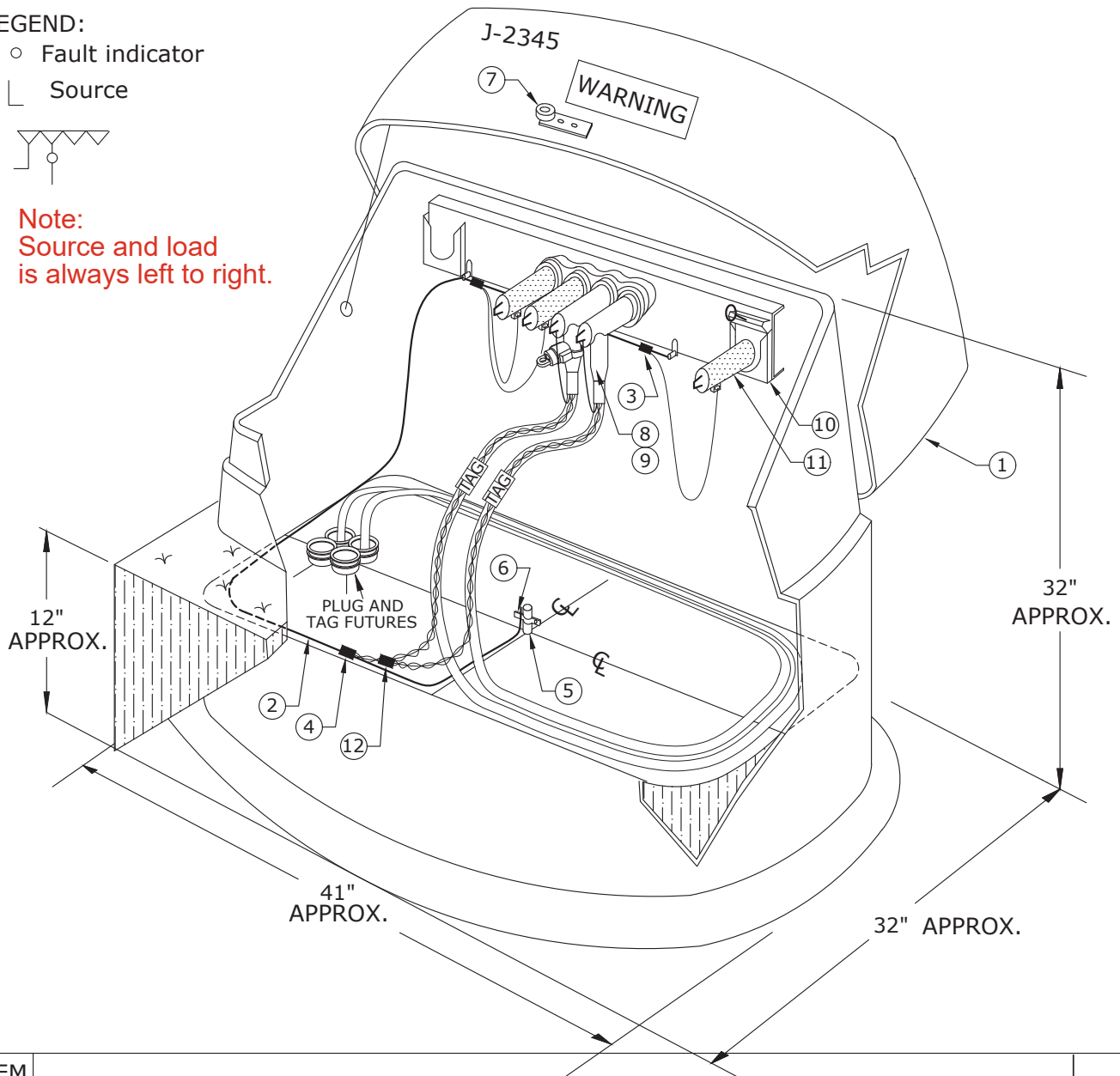

ITEM NO.	DESCRIPTION	QTY
1	Box, Junction, 1Ø, Fiberglass w/LBC4 Installed PUD PROVIDED	1
2	Conductor, Cu, #4 Solid, 1C, Bare, Soft-Drawn	15
3	Connector, Crimpet, Cu, Run & Tap #6 Sol - #4 Str (4C4)	3
4	Connector, Crimpet, Cu, Run #4 Sol - #2 Str, Tap #8 Sol - #4 Str (2C4)	1
5	Rod, Ground 5/8" x 8'	1
6	Clamp, Ground Rod, 5/8", Bronze, Small	1
7	Lock, Equipment, UG	1
8	Elbow, 200A, LB, #2, 220 mil, Test Point, 15kV, w/Jacket Seal	2
9	Indicator, Fault, UG, 400A, Test Point, Voltage Reset, 1Ø	1
10	Bushing, Standoff Insulated, 200A COMES WITH PUD PROVIDED CABINET	1
11	Cap, Protective Insulated, 200A, 15kV UG	3
12	Connector, Crimpet, Cu, Run & Tap #2 Sol - #2 Str (2C2)	2



CONSTRUCTION STANDARDS

1Ø JUNCTION BOX
4-WAY

⚠			

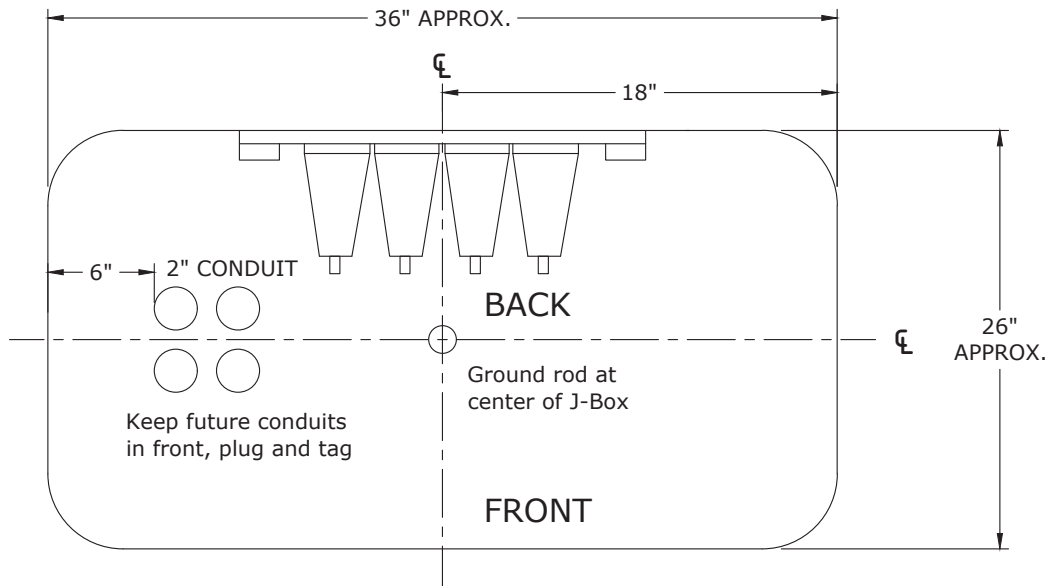

Plan View 1-Phase J-Box

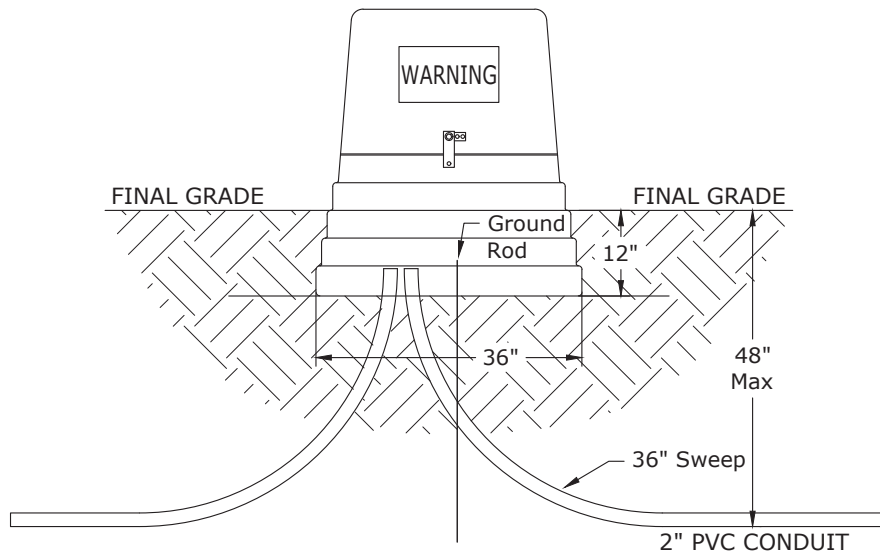

Primary J-Box Conduit Arrangement

Notes:

1. Typical elbow arrangement is shown.
2. Do not put dirt inside junction box. Space is required for cable slack and operating clearance.
3. Leave cable slack for future operations.
4. Future conduits shall be plugged w/ 2" plastic conduit plug.
5. Futures should be tagged with direction and length of conduit.
6. Proof conduit and install sequentially numbered, 2500 lb mule tape in all futures.



CONSTRUCTION STANDARDS

1Ø JUNCTION BOX
4-WAY

⚠			

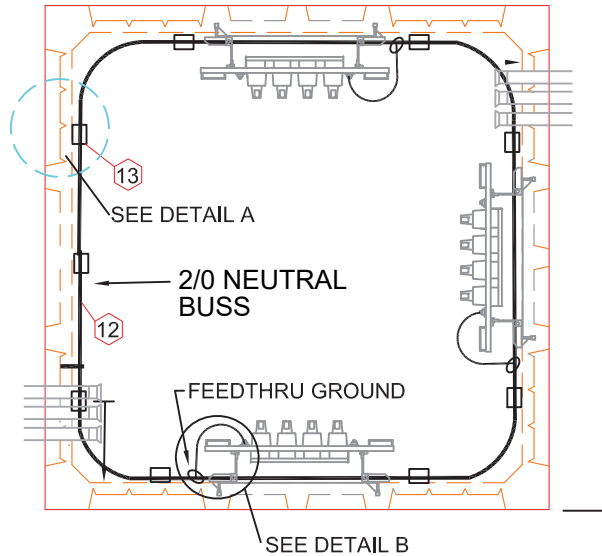

STACK 4-WAYS
PER V57/NC57
OR V77/NC77D

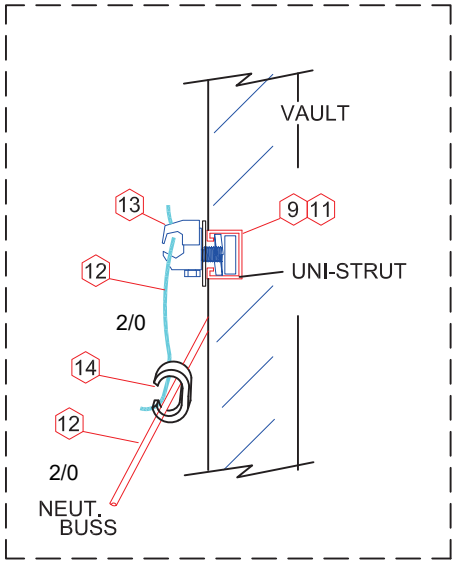

DETAIL A
NEUTRAL BUSS TO VAULT

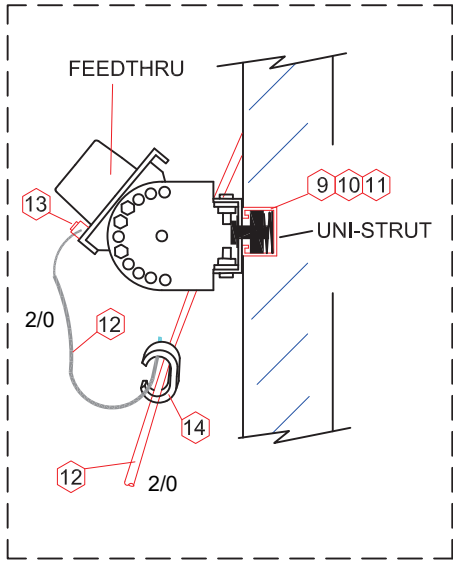

DETAIL B
FEEDTHRU GROUNDING

ITEM	DESCRIPTION	QUANTITY	
		UVG	
GROUNDING			
9	SS WASHER - 1/2" ROUND	10	
10	SS BOLT 3/4" x 1/2"	6	
11	UNI STRUT NUT 1/2"	14	
12	2/0 COPPER S/D	40'	
13	GROUND CONNECTOR 2/0	8	
14	COPPER CRIMP (2/0 - 2/0)	14	

ADDITIONAL MATERIAL NOT SHOWN:
30' :Conductor, Cu, #4 solid, 1C, Bare, Soft-drawn (Grounds for elbows, grd caps, etc.)
Qty As Reqd: Connector, Crimpet, Cu, #4 to 2/0 (Ground to Buss)

Qty As Reqd: Connector, Crimpet, Cu, 4/0 to 2/0 (Concentric to Buss)



UVG

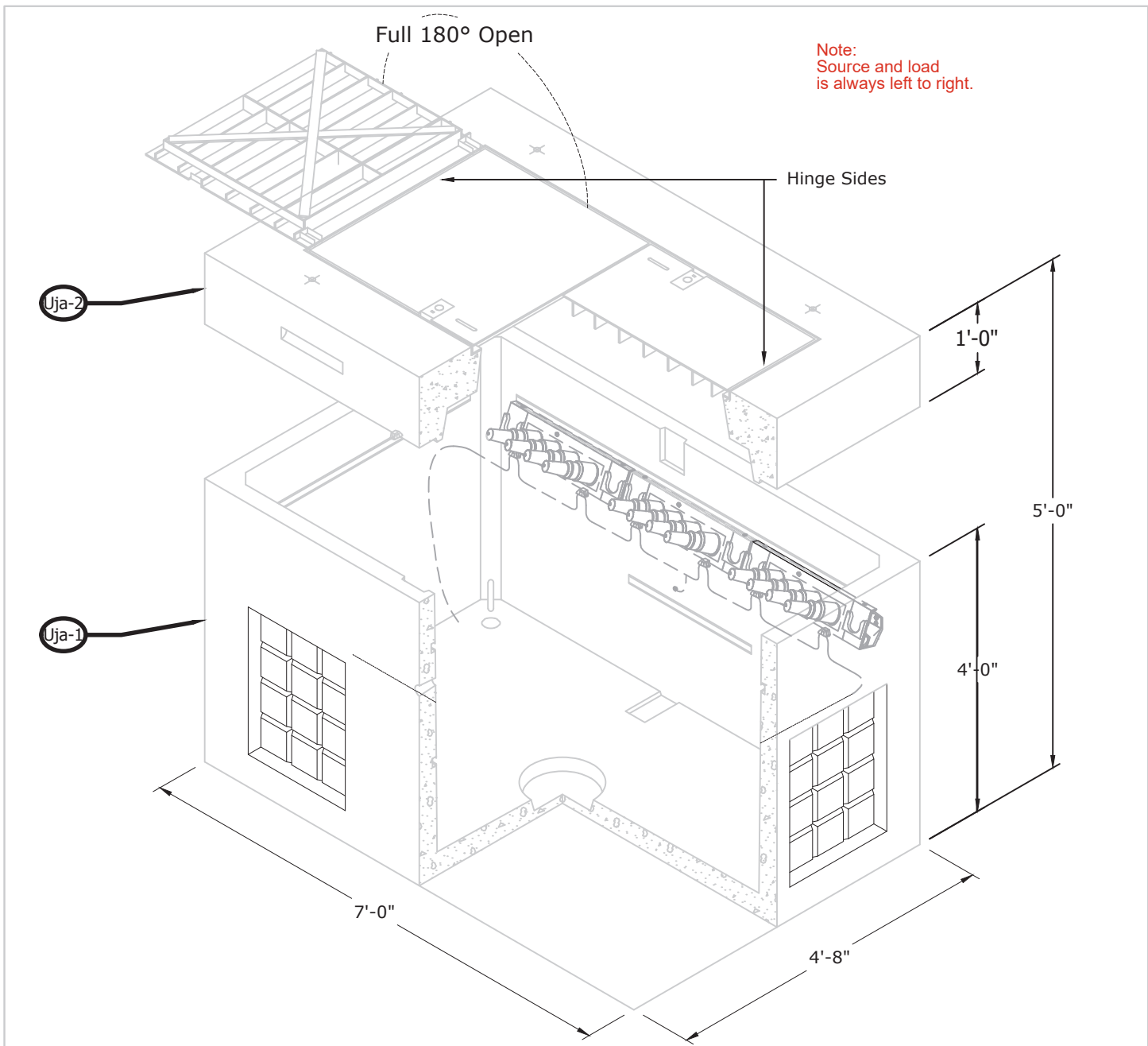

VAULT AND LID ARE PUD PROVIDED

V57			
ITEM	QTY	DESCRIPTION	ITEM#
Uja-1	10	VAULT, 575LA, UFER GROUND (SELF-GROUNDING)	76006575

VC57			
ITEM	QTY	DESCRIPTION	ITEM#
Uja-2	10	VAULT COVER, DBL DOOR, 575-LA, NON SLIP	76006554



CONSTRUCTION STANDARDS
 UNDERGROUND
 THREE-PHASE PRIMARY
 575 VAULT AND COVER

REVISIONS			
DATE	ENGR	OPS	
3/18/25	JJW	OPS	

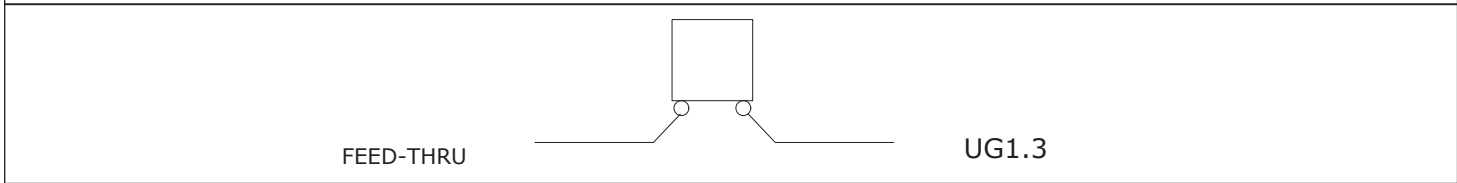
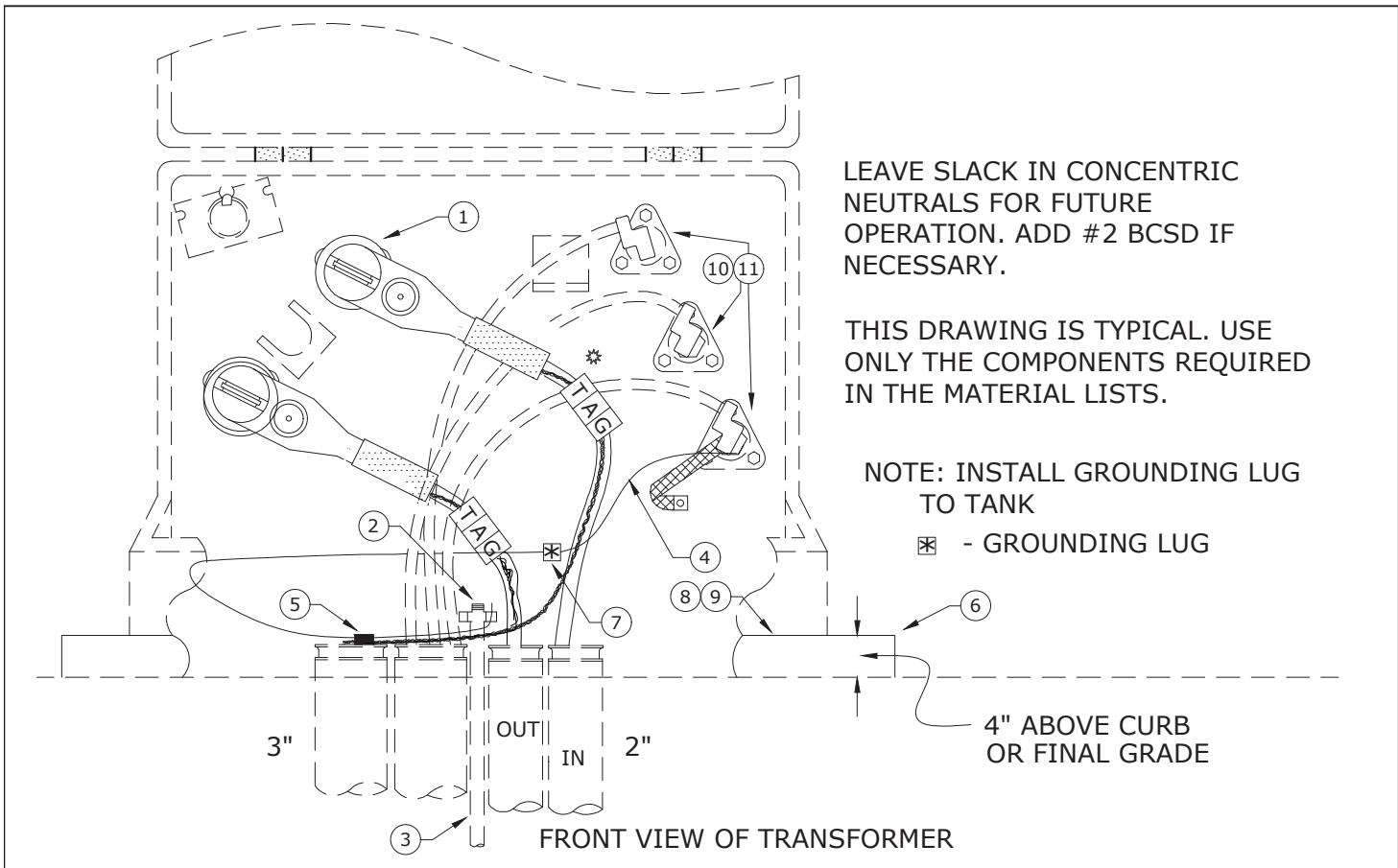

MATERIAL LIST

ITEM NO.	DESCRIPTION	UG1.3
		QTY.
1	Elbow, Loadbreak, #2, 200A, 220 mil	2
2	Clamp, Ground Rod 5/8", Small	2
3	Rod, Ground 5/8" x 8'	1
4	Conductor, Wire BSDC #4 SLD	10'
5	Connector, Crimpet, #4 to #2	2
6	Basement, Transformer 36" x 36" x 24"	1
7	Ground Lug	1
8	Bolt, Machine, 1/2" x 1-1/2" SS	2
9	Washer, 2" x 3" x 3/16" w/ 9/16" Slotted Hole	2
10	Connector, z-bar #2-500 MCM + Streetlight	3
11	Cover, Connector U.G.	3

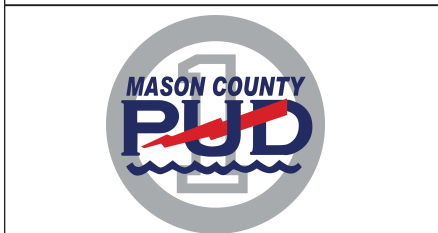

CONSTRUCTION STANDARDS

SINGLE PHASE
 PADMOUNT TRANSFORMER
 FEED-THRU

PAGE: 1 of 2

UG1.3

△			
△			

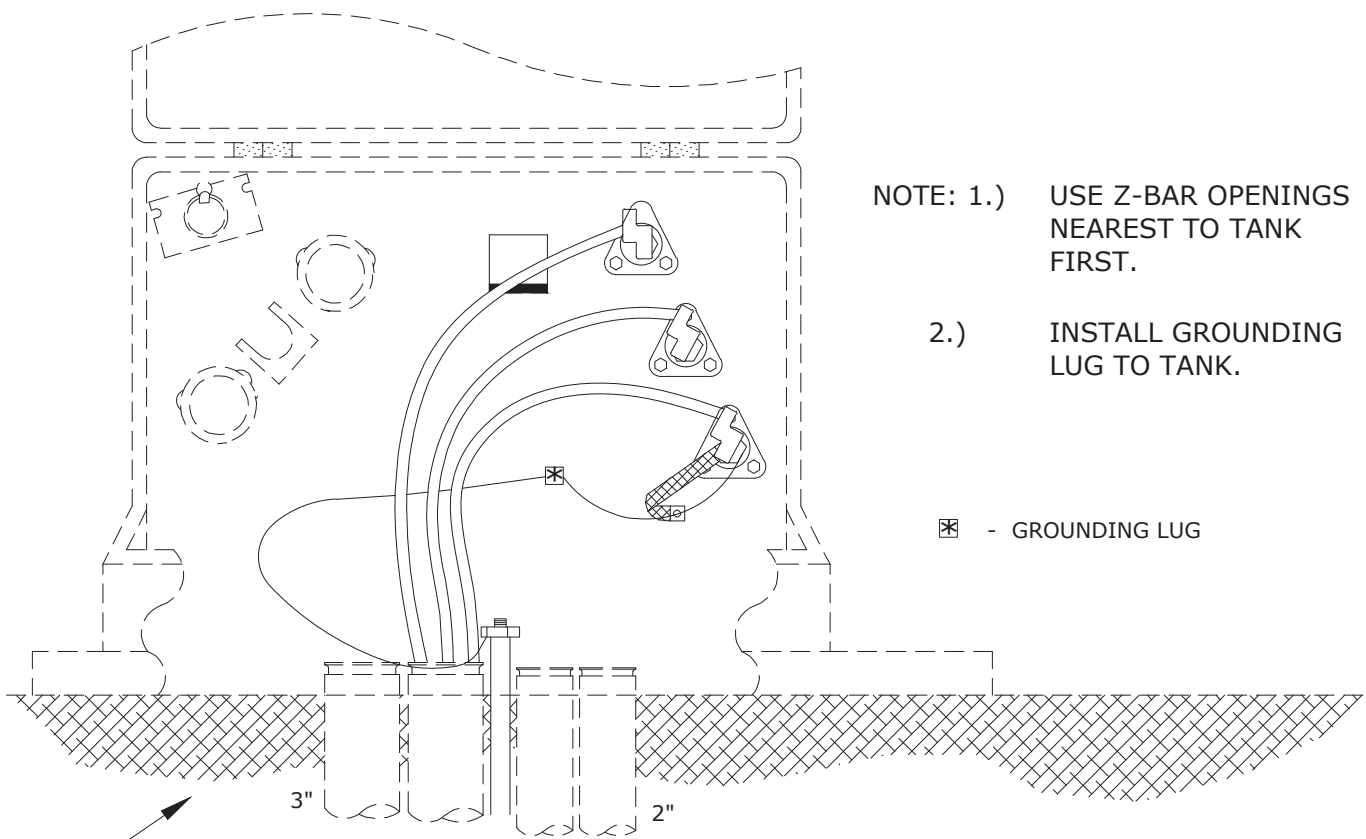

- NOTE: 1.) USE Z-BAR OPENINGS NEAREST TO TANK FIRST.
- 2.) INSTALL GROUNDING LUG TO TANK.

⊠ - GROUNDING LUG

SECONDARY CONDUITS AS NEEDED (MAXIMUM 6)

FRONT VIEW OF TRANSFORMER

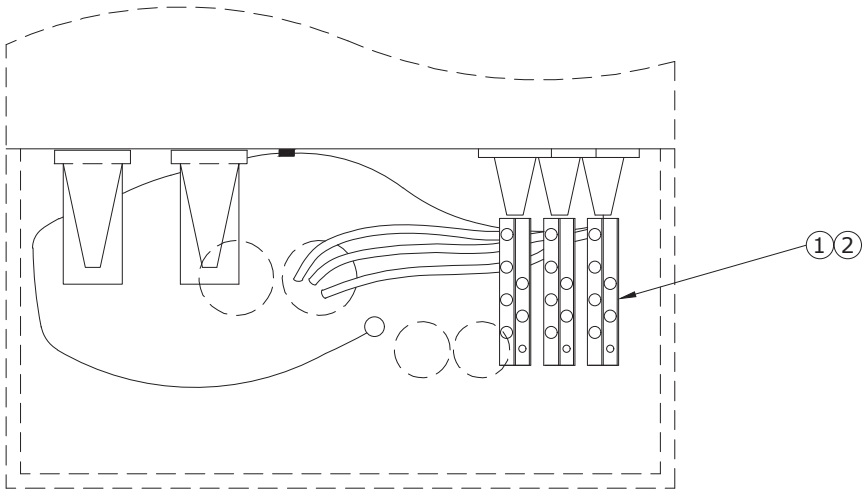

TOP VIEW OF PAD WINDOW (SHOWING CONDUIT AND CONDUCTOR LOCATION)

ITEM NO.	DESCRIPTION	UG1.3
		QTY.
1	Connector, Z-Bar #2-500KCM + St. Lt.	3
2	Cover, Connector, U.G.	3



CONSTRUCTION STANDARDS
 PADMOUNT TRANSFORMER ASSEMBLY
 SINGLE PHASE SECONDARY

⚠			
⚠			

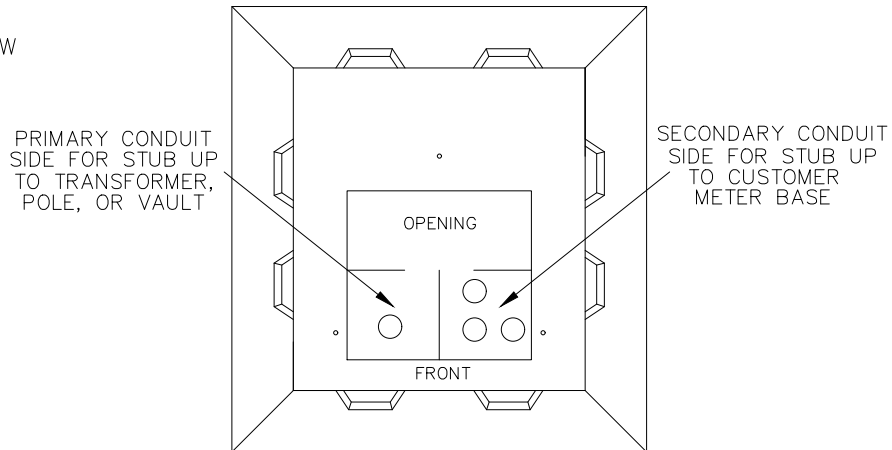

FRONT VIEW

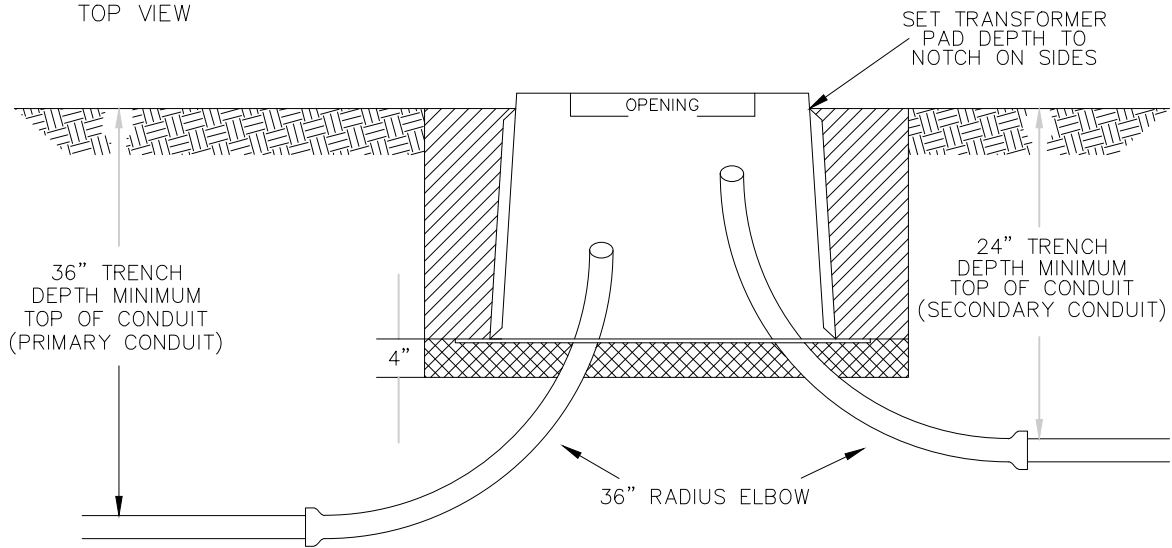

TOP VIEW



LEGEND

-  SAND OR CLEAN SOIL
-  COMPACTED BACKFILL UNLESS OTHERWISE SPECIFIED
-  UNDISTURBED EARTH

NOTES:

1. All elbows shall be whole and be inside the opening of the transformer as show above.
2. Sand or clean gravel shall be used as a level base for all transformer pads.
3. Proof conduit and install sequentially numbered, 2500 lb mule tape in all futures.



CONSTRUCTION STANDARDS
 UNDERGROUND
 TRANSFORMER RISER (NON-ENERGIZED)
 CONDUIT STUB DETAILS

REVISIONS

DATE	ENGR	OPS
3/18/25	JJW	JG

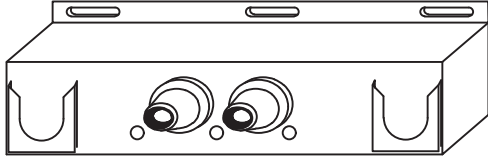

UM6.JN22 TWO POINT TERMINATION
2-200 AMP LOAD BREAK (FORMERLY UM6-20)

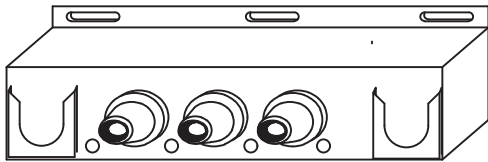

UM6.JN222 THREE POINT TERMINATION
3-200 AMP LOAD BREAK (FORMERLY UM6-21)

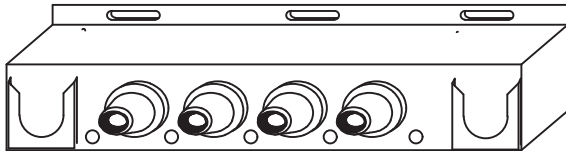

UM6.JN2222 FOUR POINT TERMINATION
4-200 AMP LOAD BREAK (FORMERLY UM6-22)

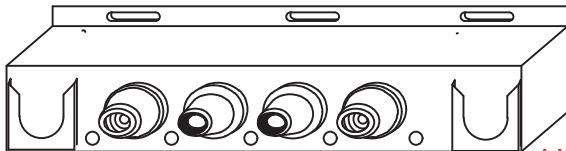

UM6.JN6226 FOUR POINT TERMINATION
2-600 AMP DEAD BREAK
2-200 AMP LOAD BREAK

UM6.JN6666

Hubbell #625-J4-U - ELASTIMOLD-DP#0568120

ITEM	QTY.	MATERIAL
Uhq	1	Multipoint junction

DEFINE THE NUMBER OF POINTS
AND TYPE OF POINT FOR EACH MODULE
2 FOR 200 AMP LOAD BREAK
6 FOR 600 AMP DEAD BREAK
9 FOR 900 AMP DEAD BREAK



MULTIPOINT JUNCTIONS

AUG 2016

RUS

UM6.JN

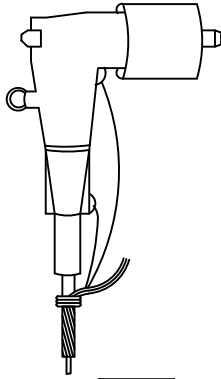

LOAD BREAK ELBOW – 200 AMP LOAD BREAK
 UM6.EL2.WIRE SIZE
 (FORMERLY UM6-1)

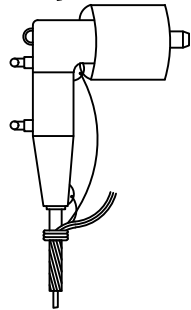

FUSED ELBOW TERMINATION 200 AMP LOAD BREAK
 UM6.EL2F.FUSE SIZE.WIRE SIZE
 UM6.EL2F.30.WIRE SIZE FOR 30 AMP FUSE
 (FORMERLY UM6-2)

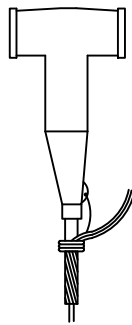

DEAD BREAK TERMINATION 600 AMP
 UM6.EL6.WIRE SIZE
 DEAD BREAK TERMINATION 900 AMP
 UM6.EL9.WIRE SIZE
 (FORMERLY UM6-3)

NOTES:
 APPEND "R" SUFFIX TO INDICATE LONGER ELBOW
 FOR REPAIR OR REPLACEMENT

ITEM	MATERIAL	UM6.EL2	UM6.EL2F	UM6.EL6	UM6.EL9
Uhp	Elbow, 200 AMP, load break	1			
Uhp	Fused elbow, 200 AMP, load break		1		
Uhb	Dead break termination, 600 AMP			1	
Uhb	Dead break termination, 900 AMP				1

	ELBOWS		
	AUG 2016		
	RUS		UM6.EL

ASSEMBLY DIAGRAM

ONE ASSEMBLY PER 600A PHASE

Note: Use torque wrench and tighten per manufacturer's specifications.

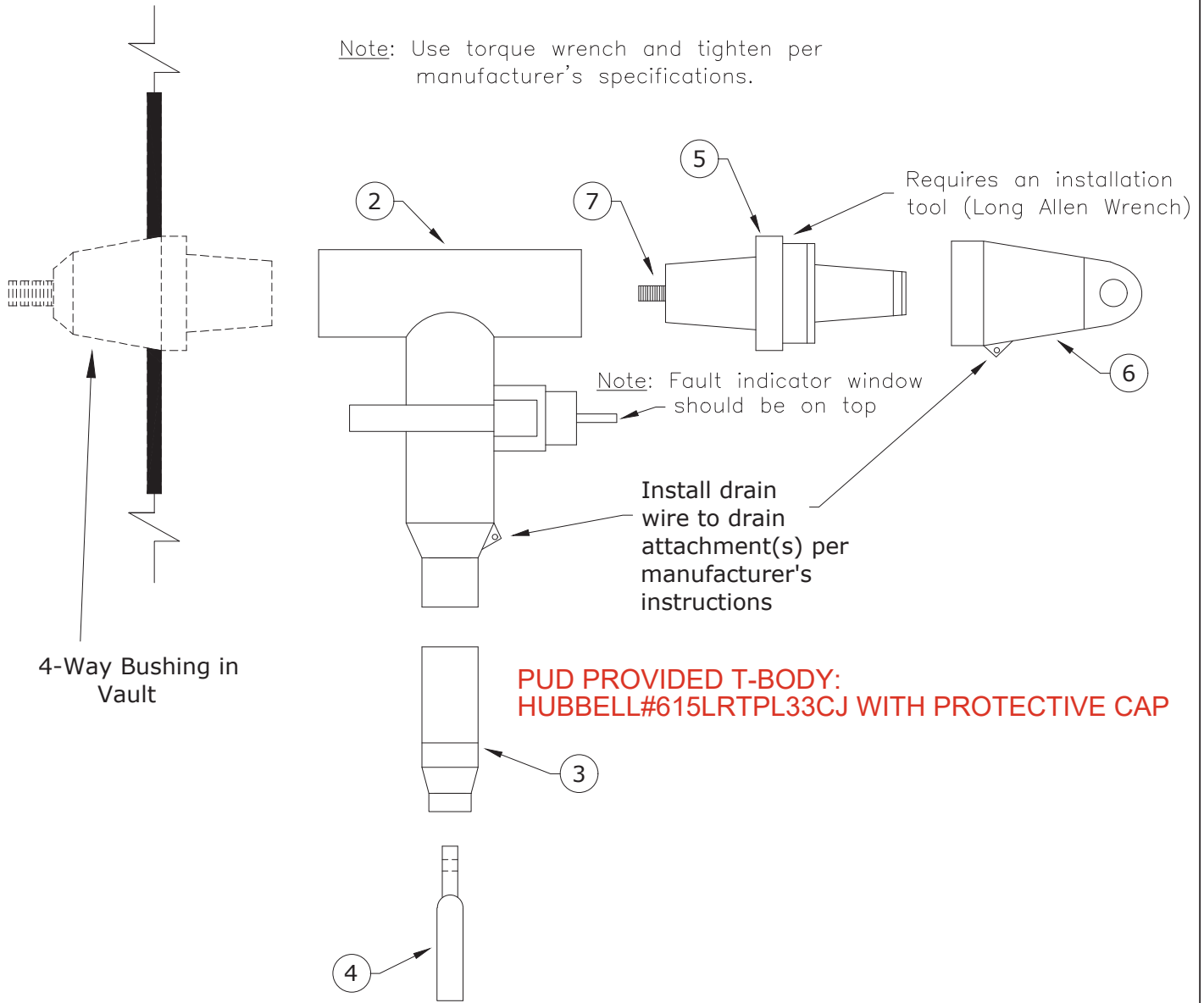

ITEM NO.	DESCRIPTION	UM6.EL6.500	
		QTY.	
1	600A Elbow Kit	1	
	<i>Each Kit Consists Of #2 to #7:</i>		
2	Housing, Elbow, 600A	1	
3	Adapter, Cable, 500 MCM	1	
4	Contact, Compression, 500 MCM, Al, Non-Threaded Hole	1	
5	Plug, Loadbreak Reducing Tap, 600A-200A	1	
6	Cap, Protective Insulated, 200A, 15kV	1	
7	Stud, Al, 600A, T-Body to Reducer Plug	1	
8	600A Elbow Sealing Kit	1	



CONSTRUCTION STANDARDS

600 AMP ELBOW - 500MCM CABLE

⚠			

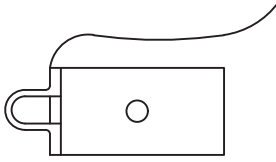

UM6.C2 INSULATED PROTECTIVE CAP
200 AMP LOAD BREAK (FORMERLY UM6-10)

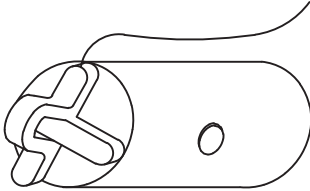

UM6.C6 INSULATED PROTECTIVE CAP
600 AMP DEAD BREAK (FORMERLY UM6-11)

Richards #K656DR - Elastimold #K656DR

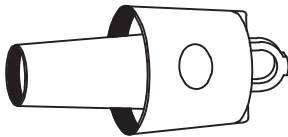

UM6.PL2 BUSHING WELL PLUG
200 AMP LOAD BREAK (FORMERLY UM6-7)

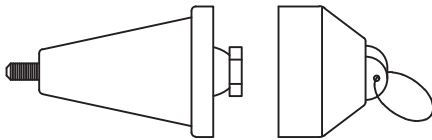

UM6.PL6 INSULATING PLUG TEE CONNECTOR
600 AMP DEAD BREAK (FORMERLY UM6-17)

NOTES:

UM6.C (CAP DESCRIPTION)
2 FOR 200 AMP LOAD BREAK CAP
6 FOR 600 AMP DEAD BREAK CAP

UM6.PL (PLUG DESCRIPTION)
2 FOR 200 AMP BUSHING WELL INSERTS
6 FOR 600 AMP TEE CONNECTOR

ITEM	MATERIAL	UM6.C2	UM6.C6	UM6.PL2	UM6.PL6
Uhb	Insulated protective cap, 200 AMP	1			
Uhb	Insulated protective cap, 600 AMP		1		
Uhb	Bushing well plug, 200 AMP			1	
Uhb	Insulating plug tee connector, 600 AMP				1



CAPS AND PLUGS

AUG 2016

RUS

UM6.C
UM6.PL

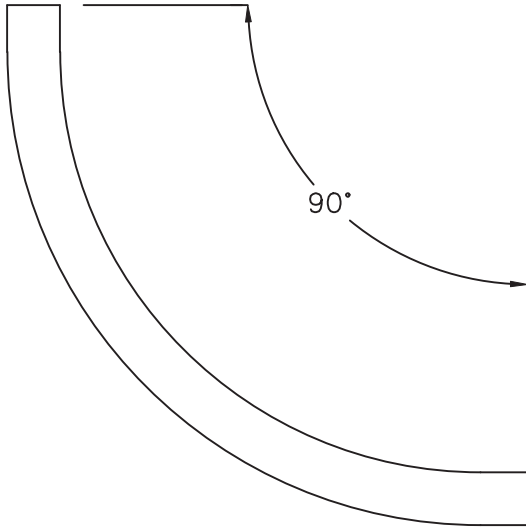

UP7.04.90

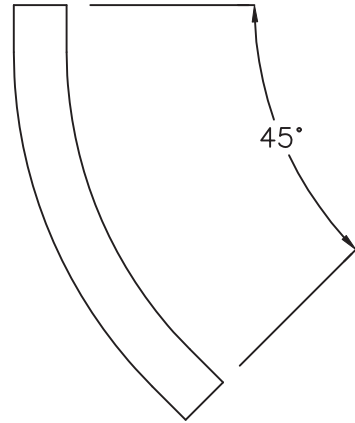

UP7.04.45

.1 = 1"
.2 = 2"
.3 = 3"

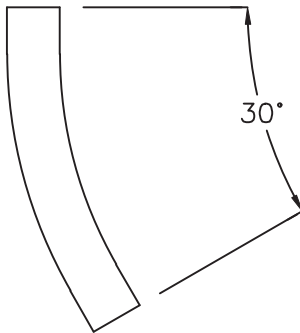

UP7.04.30

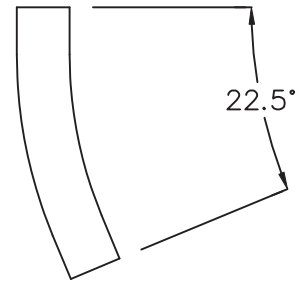

UP7.04.22

ITEM	QTY.	MATERIAL
	1	Conduit, elbow

DESIGN PARAMETERS:

SEE SECTION 8.1 FOR
MINIMUM BENDING RADIUS.

CONDUIT ELBOW

AUG 2016

RUS

UP7.04

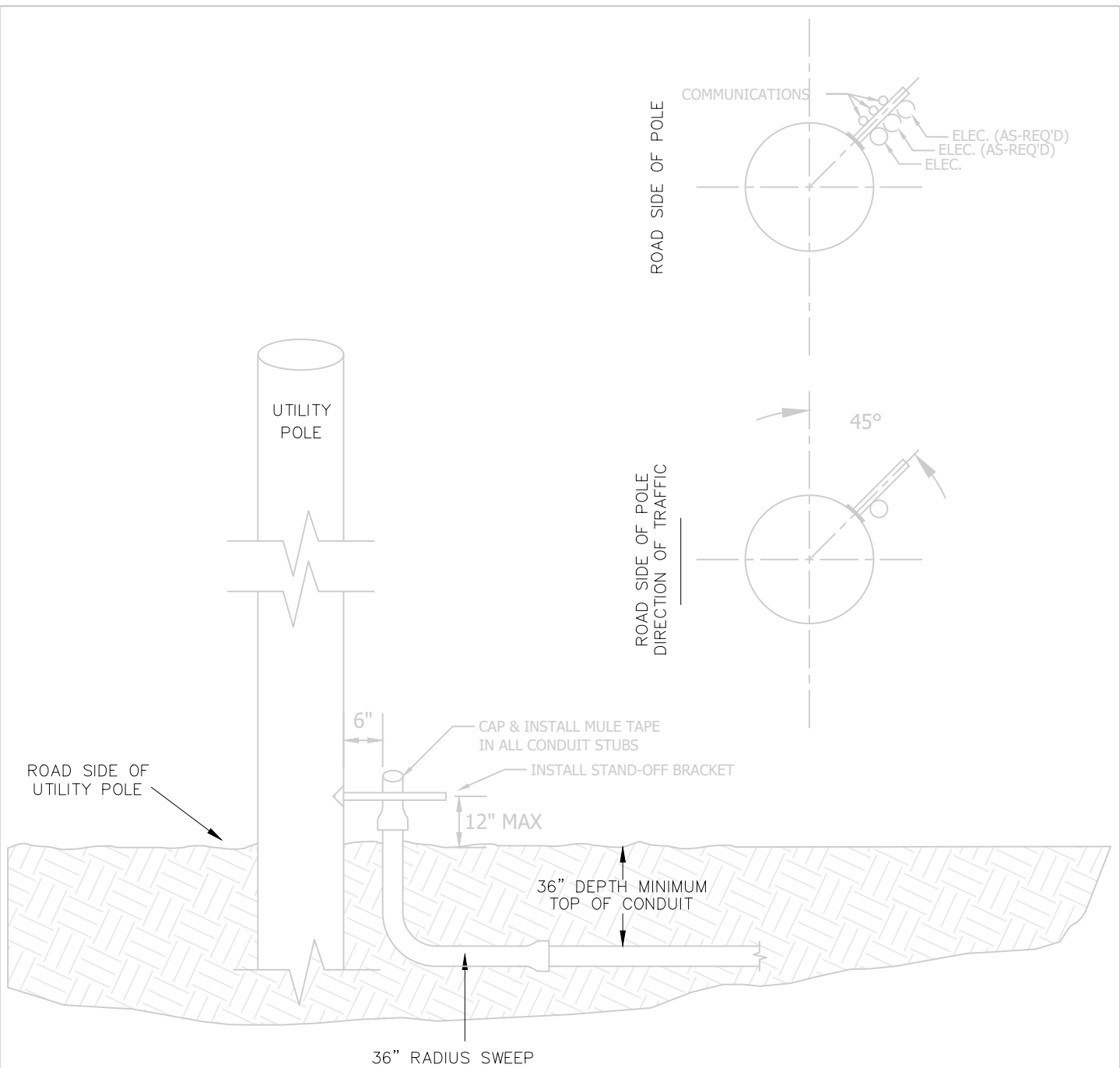

NOTES:

1. If an existing standoff/riser bracket exist at the pole, stub conduit at the existing bracket.
2. Install conduit 6" from the utility pole on the back side of the pole to the road. Use quadrant that is opposite of the direction of traffic. Location to be approved by pud.
3. Customer/contractor to install stand-off bracket. Bracket is to be supplied by customer. Use WESANCO W-1010-15-HDGAF or equivalent.
4. Conduit stub is to be level out of the ground.
5. The conduit shall be stubbed out of the ground a minimum of 6" above final grade.
6. The conduit sweep used to stub up the pole shall be a full 36" radius 90 degree sweep.
6. Proof conduit and install sequentially numbered, 2500 lb mule tape in all futures.



CONSTRUCTION STANDARDS
 UNDERGROUND
 POLE RISER
 CONDUIT STUB

REVISIONS			
DATE	ENGR	OPS	
3/18/25	JJW	JG	

PAGE: 1 of 1 **POLE STUB**

FRONT VIEW

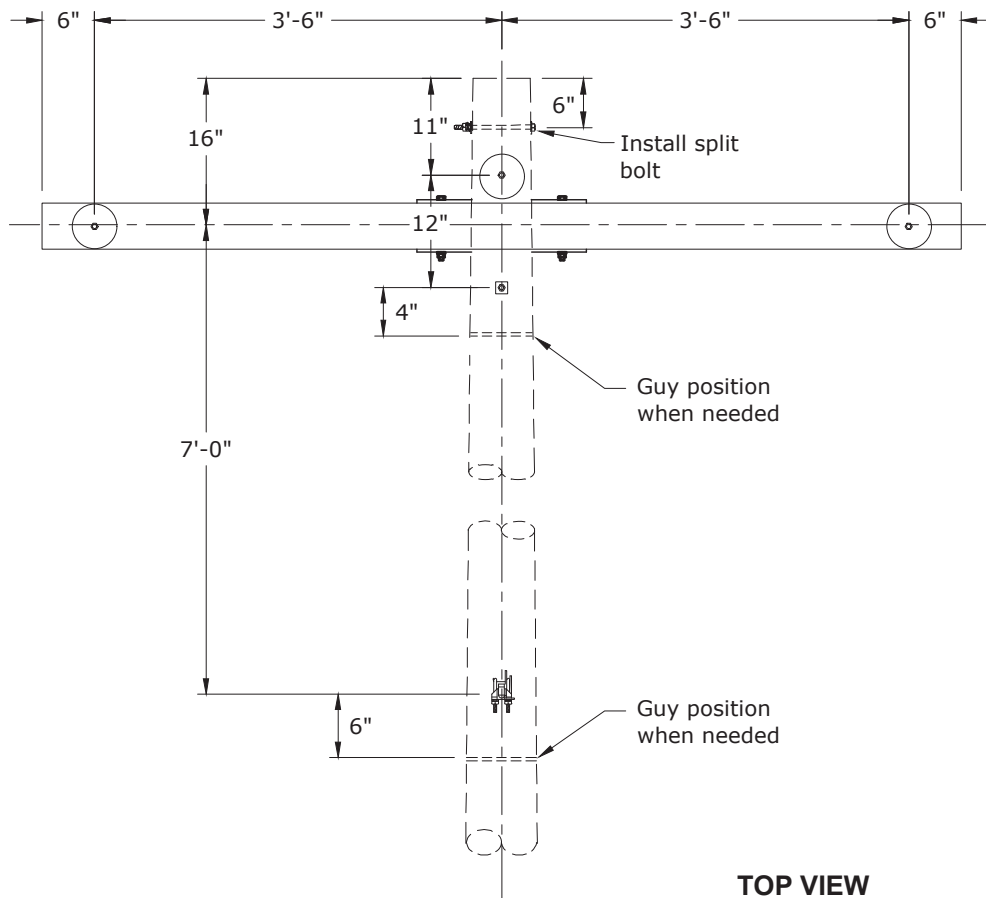

TOP VIEW

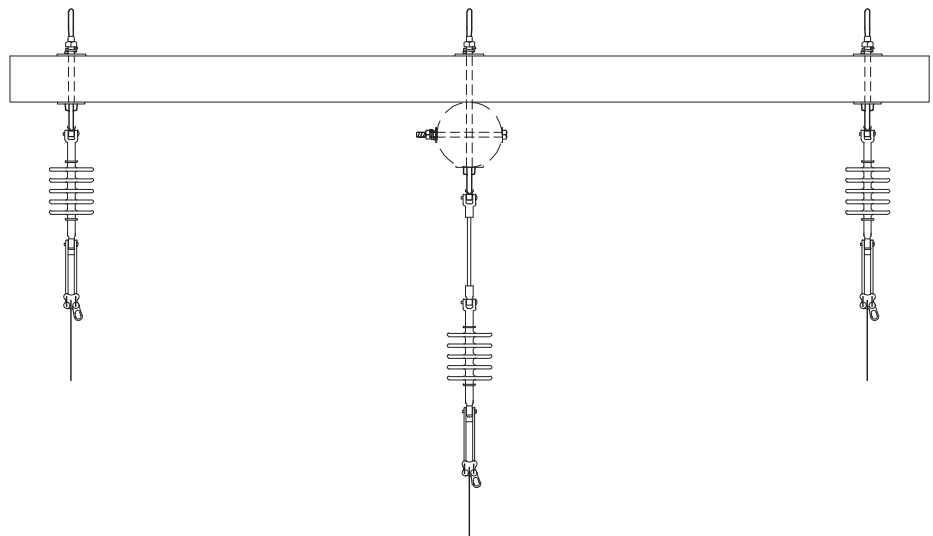

Avian Safe



CONSTRUCTION STANDARDS

8' PRE-ASSEMBLED DEADEND
336 ACSR MAX WIRE

REVISIONS

△	DATE	ENGR	OPS
△			

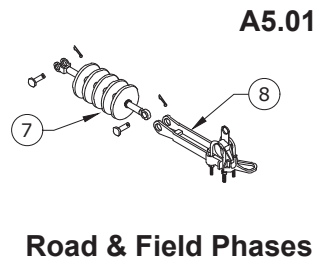
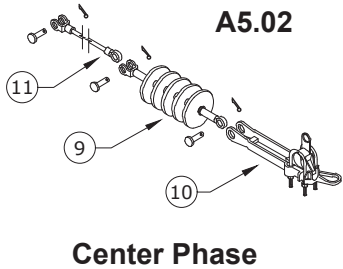
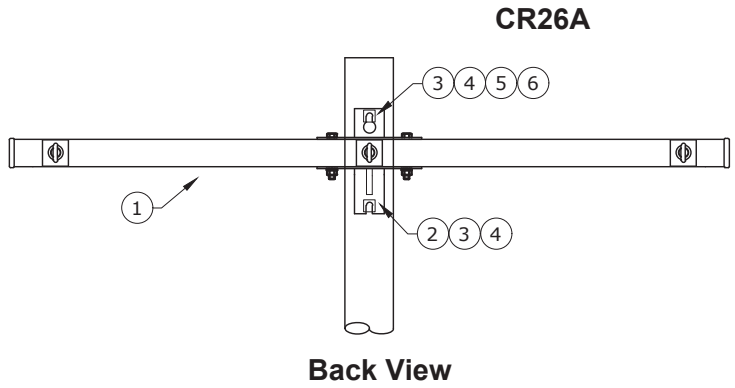
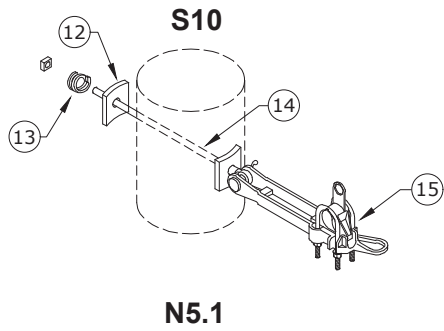

ITEM NO.	DESCRIPTION	C5.21F W2.8DEF	
		QTY.	
1	Arm, Deadend Assembly, 8', 3-position, 397 Max	1	
2	Bolt, Machine, 3/4" x 14", Galv., 18,350 lbs Ultimate Tensile	1	
3	Washer, Lock, Spring, Double Coil, Galv., 3/4"	2	
4	Washer, Curved, Square, Cast, 3" x 3" x 3/8" Thick x 13/16" Hole	2	
5	Nut, Eye Oval 3/4", Galv.	1	
6	Bolt, Machine, 3/4" x 16", Galv., 18,350 lbs Ultimate Tensile	1	
ITEM NO.	DESCRIPTION	A5.01 (2)	
		QTY.	
7	Insulator, Suspension, 15 kV Clevis-Tongue, Polymer Type	2	
8	Clamp, Strain, Distribution, #4 to 336	2	
ITEM NO.	DESCRIPTION	A5.02	
		QTY.	
9	Insulator, Suspension, 15 kV Clevis-Tongue, Polymer Type	1	
10	Clamp, Strain, Distribution, #4 to 336	1	
11	Insulator, Guy Strain, Fiberglass, 20"	1	
ITEM NO.	DESCRIPTION	N5.1	
		QTY.	
12	Washer, Curved, Square, Cast, 3" x 3" x 3/8" Thick x 13/16" Hole	2	
13	Washer, Lock, Spring, Double Coil, Galv., 5/8"	1	
14	Bolt, Eye, 5/8" x 14", Galv., 12,400 lbs Ultimate Tensile	1	
15	Clamp, Strain, Distribution, #4 - 336	1	



CONSTRUCTION STANDARDS
8' PRE-ASSEMBLED DEADEND
336 ACSR MAX WIRE

REVISIONS			
△	DATE	ENGR	OPS
△			

GUY ATTACHMENT

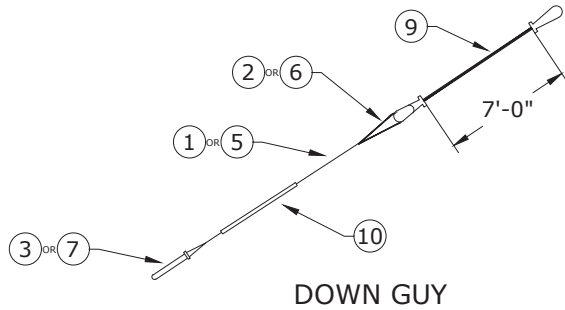
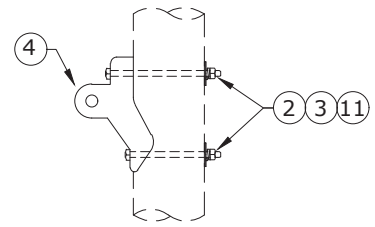

Notes:

1. If more than one guy will be attached to one anchor, an additional long automatic guy grip must be used.

ITEM NO.	DESCRIPTION	GUY ATTACH	
		QTY.	
2	Machine Bolt, 3/4" x 14", 18,350 lbs. Ultimate Tensile	2	
3	Curved Washer, Cast, 4" x 4"	2	
4	Pole Eye Plate, 21,000 lbs. Ultimate Tensile	1	
11	Double Coil Spring Lock Washer 3/4"	2	

ITEM NO.	DESCRIPTION	DOWN GUY	
		QTY.	
5	Guy Wire, 18M	45ft	
6	Guy Grip, 18M, Preformed	1	
7	Guy Grip, 18M, Automatic, Short	1	
9	Insulator, Fiberglass, 2 Wheel, 7', 21,000 lbs. Ultimate, 530kV Wet Flashover	1	
10	Marker, Guy 8' Yellow	1	



CONSTRUCTION STANDARDS

DOWN GUY

DATE			

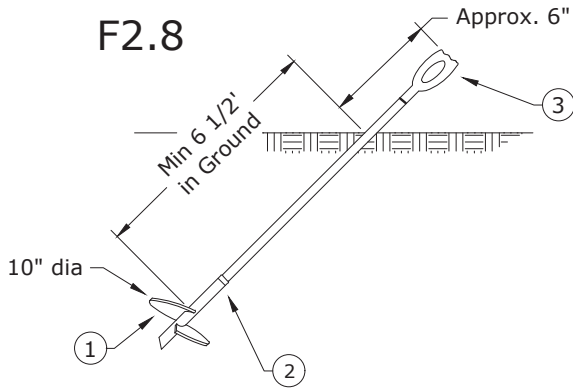

ULTIMATE HOLDING CAPACITY		
	F2.8	
Torque (ft-lbs)	(lbs)	
	10" Helix 1" x 7' Rod	14" Helix 1" x 7' Rod + 3 1/2' Rod
500	4,200	7,350
1,000	7,600	10,700
1,500	11,000	14,050
2,000	14,400	17,400
2,500	17,800	20,750
3,000	21,200	24,100
3,500	24,600	27,450
4,000	28,000	30,800
4,500	31,400	34,150
5,000	34,800	36,000

Notes:

1. A minimum of 6 1/2' of the F2.8 anchor/rod from the top of the helix must be in the ground to obtain the rated holding capacity.
2. 8" helix anchors may be used assuming that the requisite holding capacity is met.

ITEM NO.	DESCRIPTION	F2.8
		QTY.
1	10" Helix Screw Anchor, 15,000 ft-lbs.	1
2	Anchor Rod 1" x 7' - 36,000 lbs. Ultimate Tensile	1
3	Triple Eye Anchor Nut 1"	1



CONSTRUCTION STANDARDS
SINGLE HELIX SCREW ANCHORS

△			
△			

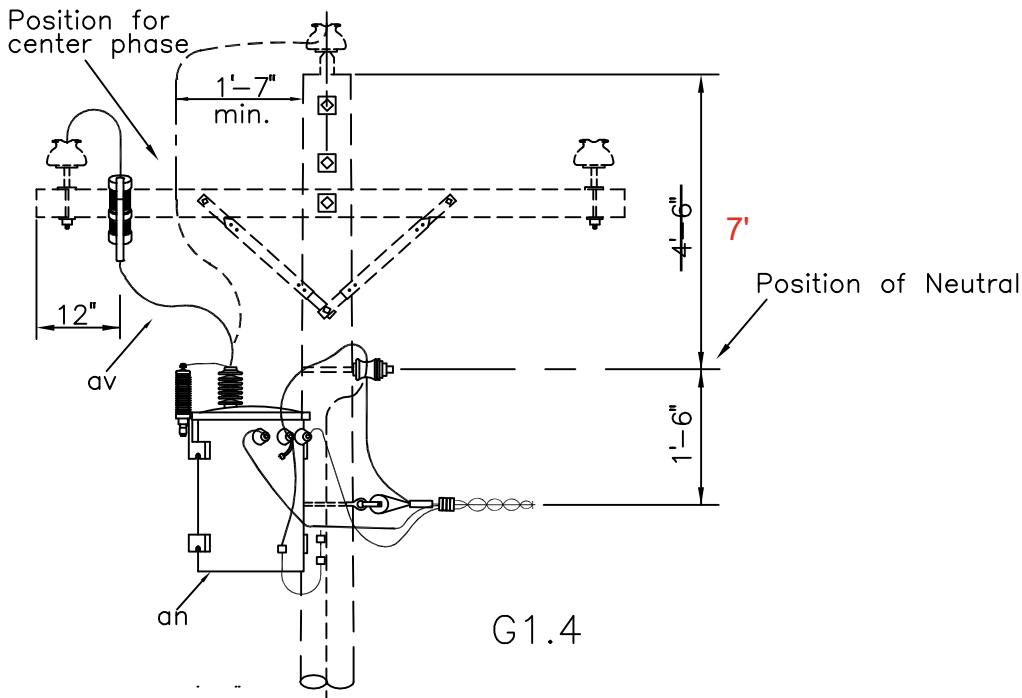

G1.4

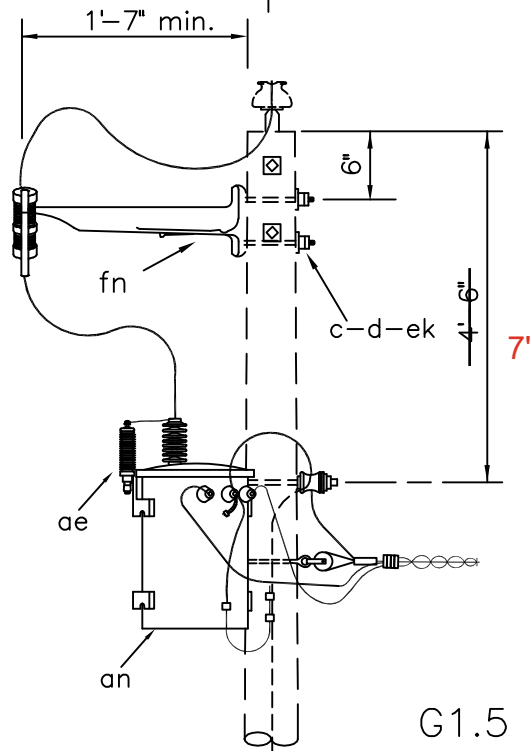

G1.5

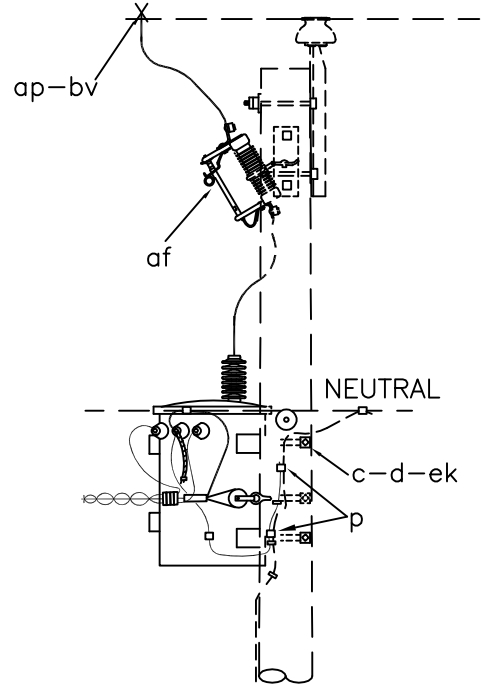

NOTE: Rotate cutout so the blade faces climbing face of pole.

ASSEMBLY: G1		.4	.5
ITEM	MATERIAL	QTY	QTY
c	Bolt, machine, 5/8" x req'd length	2	4
d	Washer, square, 2 1/4"	2	4
p	Connectors, as req'd		
ae	Arrester, surge (9 kV)	1	1
af	Cutout, dist., open (15 kV)	1	1
an	Transformer, 12.47 kV, conventional	1	1

ASSEMBLY: G1		.4	.5
ITEM	MATERIAL	QTY	QTY
ap	Clamp, hot line	1	1
av	Jumpers, stranded, as req'd		
bv	Rod, armor, as req'd		
ek	Locknuts,	2	4
fn	Bracket, extension		1

DESIGN PARAMETERS:

See Guide Drawing "G1.1G"

SINGLE-PHASE, CONVENTIONAL TRANSFORMER (TANGENT POLE)

APRIL 2005

RUS

12.47/7.2 kV

G1.4

G1.5

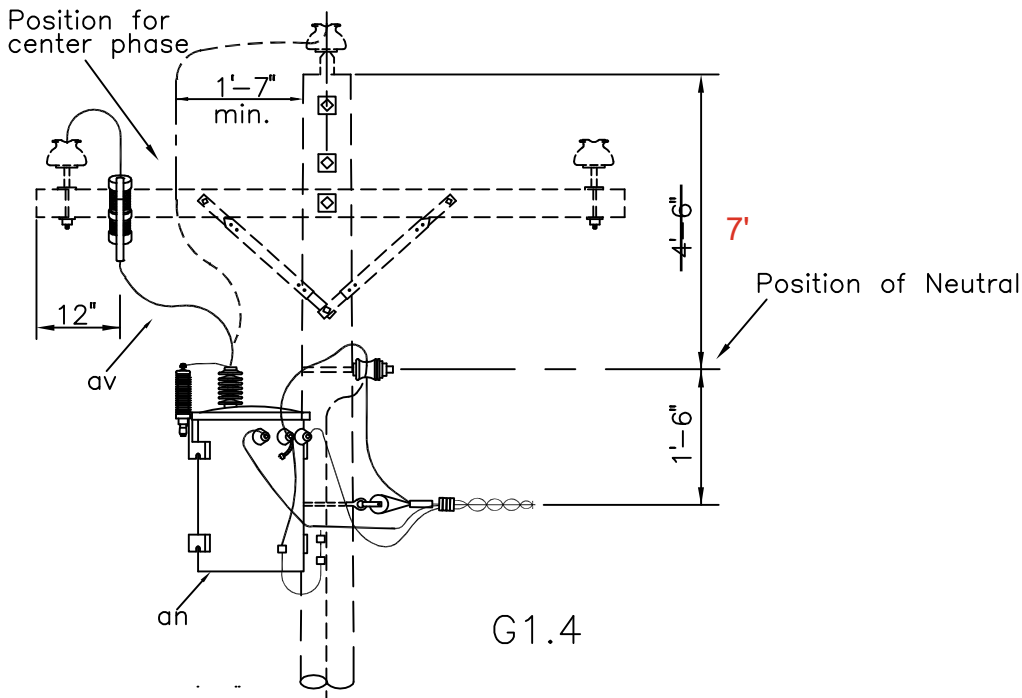

G1.4

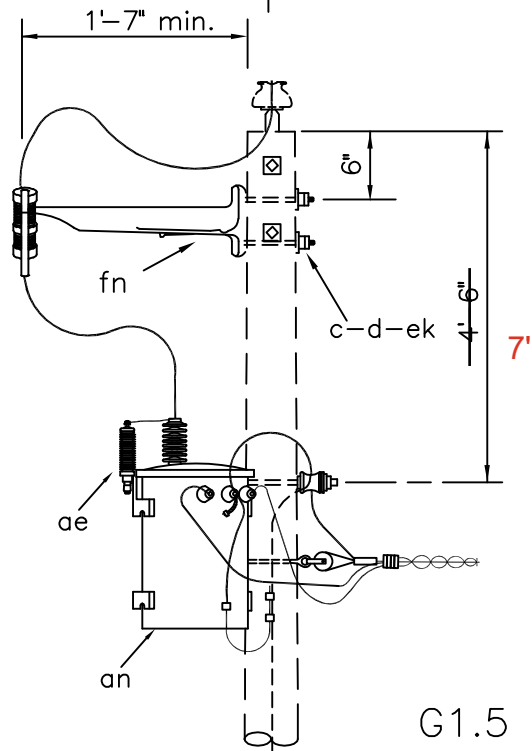

G1.5

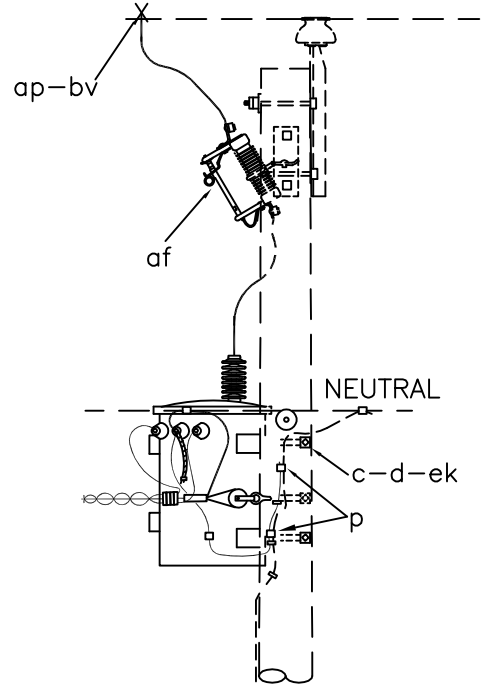

NOTE: Rotate cutout so the blade faces climbing face of pole.

ASSEMBLY: G1		.4	.5
ITEM	MATERIAL	QTY	QTY
c	Bolt, machine, 5/8" x req'd length	2	4
d	Washer, square, 2 1/4"	2	4
p	Connectors, as req'd		
ae	Arrester, surge (9 kV)	1	1
af	Cutout, dist., open (15 kV)	1	1
an	Transformer, 12.47 kV, conventional	1	1

ASSEMBLY: G1		.4	.5
ITEM	MATERIAL	QTY	QTY
ap	Clamp, hot line	1	1
av	Jumpers, stranded, as req'd		
bv	Rod, armor, as req'd		
ek	Locknuts,	2	4
fn	Bracket, extension		1

DESIGN PARAMETERS:

See Guide Drawing "G1.1G"

SINGLE-PHASE, CONVENTIONAL TRANSFORMER (TANGENT POLE)

APRIL 2005

RUS

12.47/7.2 kV

G1.4
G1.5

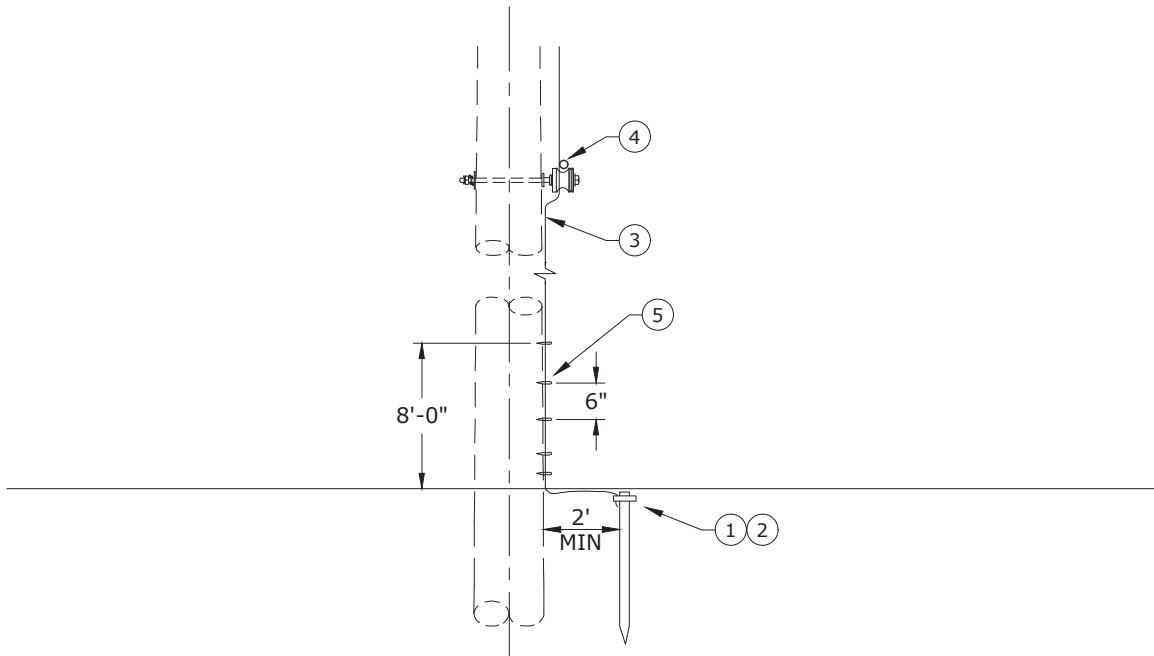

- Notes:**
1. Staple every 6" from ground line up to 8' above ground.
 2. Top of rod must be below final grade.

ITEM NO.	DESCRIPTION	H1.1
		QTY
1	Rod, Ground, 5/8" x 8'	1
2	Clamp, Ground Rod, 5/8", Small, Bronze	1
3	Conductor, Copper-Clad Steel, Black w/ Green Stripe, #4 Cu Equivalent, 40% Annealed	40
4	Connector, H-Tap, Al/Cu, Run #2-2/0 Str - Tap #6-#1 Str *	1
5	Staple, Ground, Barbed, Galvanized, 1 1/2"	24



CONSTRUCTION STANDARDS
BASIC UNITS
GROUNDING

⚠			