

## WEATHER CRITERIA

PUD1
5/1/2023

Description	Air Density Factor (Q) (psf/mph^2)	Wind Velocity (mph)	Wind Pressure (psf)	Wire Ice Thickness (in)	Wire Ice Density (lbs/ft^3)	Wire Ice Load (lbs/ft)	Wire Temp. (deg F)	NESC Constant (lbs/ft)	Wire Gust Response Factor
NESC Medium (250B)	0.00256	39.5285	4	0.25	57	0	0	0.2	1
Extreme Wind (250C)	0.00256	85	18.496	0	0	0	60	0	NESC 2017
Concurrent Ice/Wind (250D)	0.00256	50	6.4	0.25	57	0	15	0	1
Extreme Ice	0.00256	0	0	0.5	57	0	30	0	1
Uplift	0.00256	0	0	0	0	0	-5	0	1
Maximum Operating	0.00256	0	0	0	0	0	167	0	1
NESC Blowout 6PSF	0.00256	48.4123	6	0	0	0	60	0	1
No Wind (SWING 1)	0.00256	0	0	0	0	0	60	0	1
Moderate Wind (SWING 2)	0.00256	48.4123	6	0	0	0	32	0	1
Moderate Wind (SWING 3)	0.00256	48.4123	6	0	0	0	60	0	1
High Wind (SWING 4)	0.00256	90	20.736	0	0	0	60	0	1
GALLOPING (SWING)	0.00256	27.9508	2	0.5	57	0	32	0	1
GALLOPING (SAG)	0.00256	0	0	0.5	57	0	32	0	1
-20 Deg F	0.00256	0	0	0	0	0	-20	0	1
0 Deg F	0.00256	0	0	0	0	0	0	0	1
30 Deg F	0.00256	0	0	0	0	0	30	0	1
32 Deg F	0.00256	0	0	0.5	57	0	32	0	1
60 Deg F	0.00256	0	0	0	0	0	60	0	1
90 Deg F	0.00256	0	0	0	0	0	90	0	1
120 Deg F	0.00256	0	0	0	0	0	120	0	1
167 Deg F	0.00256	0	0	0	0	0	167	0	1
212 Deg F	0.00256	0	0	0	0	0	212	0	1

## SAFETY FACTORS

PUD1
5/1/2023

### Overload Factors

	Grade B	Grade C
Vertical loads	1.50	1.90
Transverse loads (wind)	2.50	2.20
Transverse loads (wire tension)	1.65	1.30
Longitudinal loads (wire tension at angles)	1.33	1.10
Longitudinal loads (wire tension at deadends)	1.65	1.30
Strength factor for wood	0.65	0.85

**Data source:**

1. Vertical loads: NESC table 253-1.
2. Transverse loads (wind): NESC table 253-1.
3. Transverse loads (wire tension): NESC table 253-1. [Crossing span safety factor is used for grade C construction]
4. Longitudinal loads (wire tension at angles): NESC table 253-1 for grade C, RUS bulletin #1724E-200 table 11-6 for grade B
5. Longitudinal loads (wire tension at deadends): NESC table 253-1.
6. Strength factor for wood: NESC table 261-1A.

**OVERHEAD VERTICAL WIRE CLEARANCES OVER GROUND**  
**lowest point on the conductor during worst case sag condition**

Nature of surface underneath wires, conductors, or cables	Ins. Comm. Cable, multi-grounded neutrals, grounded guys & triplex serv. Cable			NESC RUS PUD1
	23.5 25.5 <b>27</b>	24 26 <b>27.5</b>	24.5 26.5 <b>28.5</b>	
1. Track rails of railroads (except electrified railroads using overhead trolley conductors)	15.5 17.5 <b>19</b>	16 18 <b>19</b>	18.5 20.5 <b>20.5</b>	NESC RUS PUD1
2. Public roads, streets, alleys and other areas subject to truck traffic.	15.5 17.5 <b>17.5</b>	16 18 <b>18</b>	18.5 20.5 <b>20.5</b>	NESC RUS PUD1
3. Private roads and other land traversed by vehicles (cultivated, grazing, forest, etc.)	9.5 11.5 <b>11.5</b>	12 14 <b>14</b>	14.5 16.5 <b>16.5</b>	NESC RUS PUD1
4. Spaces and ways for pedestrians only (cannot ride horses). Spaces created by fences/gates do not qualify *	24 <b>24***</b>	24 <b>24</b>	30 <b>30</b>	WSDOT PUD1
5. INTERSTATES & STATE HIGHWAYS (crossings) **				

**Where wires, conductors, or cables run along and within the limits of highways or other road rights-of-way but do not overhang the roadway**

6. Public roads, streets or alleys	15.5 17.5 <b>17.5</b>	16 18 <b>18</b>	18.5 20.5 <b>20.5</b>	NESC RUS PUD1
7. INTERSTATES & STATE HIGHWAYS (longitudinal)	20 <b>20</b>	24 <b>24</b>	27 <b>27</b>	WSDOT PUD1

\* These spaces must be the result of a physical terrain feature (a steep bank) where vehicles or horses cannot traverse or a man made feature not easily modified for vehicles (a cat walk)

\*\* Refer to WAC 468-34-290 for more information

\*\*\* Communication joint use with electrical may be 20' per WAC 468-34-290

# GENERAL STRINGING OUTSIDE OF STRINGING SPECIFICATION



SPIDA®silk v7.3.2									
Report Date: 02/01/2022									
<b>4/0 PENGUIN (6/1) - Initial Sags and Tensions</b>									
<b>Ruling Span: 250'</b>									
<b>Temperature (°F)</b>	20	30	40	50	60	70	80	90	100
<b>Horizontal Tension (lbf)</b>	2107	1952	1797	1642	1489	1342	1203	1074	960
<b>Span Distance (ft)</b>	<b>Sag (inches)</b>								
150	4	5	5	6	6	7	8	9	10
200	8	9	9	10	11	12	14	15	17
250	12	13	14	16	17	19	22	24	27
300	18	19	21	23	25	28	31	35	39
350	24	26	28	31	34	38	42	47	53

<b>Wire Properties</b>	
Size	4/0 PENGUIN
Diameter	0.563"
Weight Per Length	0.277 lbf/ft
Description	PENGUIN
Stranding	6/1
Number of Conductors	1
Strength	7690 lbf



## GUYING AND ANCHORING

PUD1
05/01/23

Conductor size & type	4/0 ACSR 6/1 Penguin	
Maximum conductor tension	2662	Lbs
Number of conductors	4	
Telephone	Yes	
Phase to neutral distance	7	Ft
NESC Grade of Construction	C	
Working guy tension	15597.5	Lbs
Working anchor tension	21200	Lbs

### Number of Guy Leads and Anchors

Dead-end	Pole Height		
Shortest lead length	45	50	55
5	N/A	N/A	N/A
10	3,3	N/A	N/A
15	3,3	3,3	3,3
20	2,2	3,3	3,3
25	2,2	2,2	3,3
35	2,2	2,2	2,2
40	2,2	2,2	2,2

Angles		Pole Height= 45 Ft							
Shortest lead length	Angle=	5	10	15	20	30	40	50	60
5		1,1	2,1	2,2	2,2	3,3	3,3	N/A	N/A
10		1,1	1,1	2,1	2,1	2,2	3,3	3,3	3,3
15		1,1	1,1	1,1	2,1	2,2	2,2	3,3	3,3
20		1,1	1,1	1,1	1,1	2,1	2,2	2,2	2,2
25		1,1	1,1	1,1	1,1	2,1	2,1	2,2	2,2
35		1,1	1,1	1,1	1,1	1,1	2,1	2,1	2,2

Angles		Pole Height= 50 Ft							
Shortest lead length	Angle=	5	10	15	20	30	40	50	60
5		1,1	2,2	2,2	2,2	3,3	N/A	N/A	N/A
10		1,1	1,1	2,1	2,2	2,2	3,3	3,3	N/A
15		1,1	1,1	1,1	2,1	2,2	2,2	3,3	3,3
20		1,1	1,1	1,1	1,1	2,1	2,2	2,2	3,3
25		1,1	1,1	1,1	1,1	2,1	2,2	2,2	2,2
35		1,1	1,1	1,1	1,1	1,1	2,1	2,2	2,2

Angles		Pole Height= 55 Ft							
Shortest lead length	Angle=	5	10	15	20	30	40	50	60
5		1,1	2,2	2,2	3,3	3,3	N/A	N/A	N/A
10		1,1	1,1	2,1	2,2	3,3	3,3	3,3	N/A
15		1,1	1,1	1,1	2,1	2,2	2,2	3,3	3,3
20		1,1	1,1	1,1	1,1	2,1	2,2	3,3	3,3
25		1,1	1,1	1,1	1,1	2,1	2,2	2,2	3,3
35		1,1	1,1	1,1	1,1	1,1	2,1	2,2	2,2

Output information is in the format of <# of down guys>, <# of anchors>. Minimum guy spacing is 5'.

# GENERAL STRINGING OUTSIDE OF STRINGING SPECIFICATION



SPIDA®silk v7.3.2									
Report Date: 02/01/2022									
<b>1/0 RAVEN (6/1) - Initial Sags and Tensions</b>									
<b>Ruling Span: 250'</b>									
<b>Temperature (°F)</b>	20	30	40	50	60	70	80	90	100
<b>Horizontal Tension (lbf)</b>	1173	1096	1019	940	862	785	709	637	570
<b>Span Distance (ft)</b>	<b>Sag (inches)</b>								
150	4	4	5	5	5	6	7	7	8
200	7	8	8	9	10	11	12	13	15
250	11	12	13	14	15	16	18	20	23
300	16	17	18	20	22	24	26	29	33
350	22	23	25	27	29	32	36	40	45

<b>Wire Properties</b>	
Size	1/0 RAVEN
Diameter	0.398"
Weight Per Length	0.138 lbf/ft
Description	RAVEN
Stranding	6/1
Number of Conductors	1
Strength	4250 lbf

## GUYING AND ANCHORING

PUD1
05/02/25

Conductor size & type	1/0 ACSR 6/1 Raven	
Maximum conductor tension	1534	Lbs
Number of conductors	4	
Telephone	No	
Phase to neutral distance	7	Ft
NESC Grade of Construction	C	
Working guy tension	15597.5	Lbs
Working anchor tension	21200	Lbs

### Number of Guy Leads and Anchors

Dead-end	Pole Height		
Shortest lead length	45	50	55
5	3,3	3,3	3,3
10	2,2	2,2	2,2
15	2,1	2,2	2,2
20	2,1	2,1	2,1
25	1,1	1,1	2,1
35	1,1	1,1	1,1
40	1,1	1,1	1,1

Angles		Pole Height= 45 Ft							
Shortest lead length	Angle=	5	10	15	20	30	40	50	60
5		1,1	1,1	1,1	2,1	2,2	2,2	2,2	3,3
10		1,1	1,1	1,1	1,1	2,1	2,1	2,2	2,2
15		1,1	1,1	1,1	1,1	1,1	1,1	2,1	2,1
20		1,1	1,1	1,1	1,1	1,1	1,1	1,1	2,1
25		1,1	1,1	1,1	1,1	1,1	1,1	1,1	1,1
35		1,1	1,1	1,1	1,1	1,1	1,1	1,1	1,1

Angles		Pole Height= 50 Ft							
Shortest lead length	Angle=	5	10	15	20	30	40	50	60
5		1,1	1,1	2,1	2,2	2,2	2,2	3,3	3,3
10		1,1	1,1	1,1	1,1	2,1	2,2	2,2	2,2
15		1,1	1,1	1,1	1,1	1,1	2,1	2,1	2,2
20		1,1	1,1	1,1	1,1	1,1	1,1	1,1	2,1
25		1,1	1,1	1,1	1,1	1,1	1,1	1,1	1,1
35		1,1	1,1	1,1	1,1	1,1	1,1	1,1	1,1

Angles		Pole Height= 55 Ft							
Shortest lead length	Angle=	5	10	15	20	30	40	50	60
5		1,1	1,1	2,1	2,2	2,2	3,3	3,3	3,3
10		1,1	1,1	1,1	1,1	2,1	2,2	2,2	2,2
15		1,1	1,1	1,1	1,1	1,1	2,1	2,1	2,2
20		1,1	1,1	1,1	1,1	1,1	1,1	2,1	2,1
25		1,1	1,1	1,1	1,1	1,1	1,1	1,1	2,1
35		1,1	1,1	1,1	1,1	1,1	1,1	1,1	1,1

Output information is in the format of <# of down guys>, <# of anchors>. Minimum guy spacing is 5'.

## GUYING AND ANCHORING

PUD1
05/02/25

Conductor size & type	#4 ACSR 7/1 Swanate	
Maximum conductor tension	914	Lbs
Number of conductors	2	
Telephone	No	
Phase to neutral distance	7	Ft
NESC Grade of Construction	C	
Working guy tension	15597.5	Lbs
Working anchor tension	21200	Lbs

### Number of Guy Leads and Anchors

Dead-end	Pole Height		
Shortest lead length	45	50	55
5	2,1	2,1	2,1
10	1,1	1,1	1,1
15	1,1	1,1	1,1
20	1,1	1,1	1,1
25	1,1	1,1	1,1
35	1,1	1,1	1,1
40	1,1	1,1	1,1

Angles		Pole Height= 45 Ft							
Shortest lead length	Angle=	5	10	15	20	30	40	50	60
5		1,1	1,1	1,1	1,1	1,1	1,1	1,1	2,1
10		1,1	1,1	1,1	1,1	1,1	1,1	1,1	1,1
15		1,1	1,1	1,1	1,1	1,1	1,1	1,1	1,1
20		1,1	1,1	1,1	1,1	1,1	1,1	1,1	1,1
25		1,1	1,1	1,1	1,1	1,1	1,1	1,1	1,1
35		1,1	1,1	1,1	1,1	1,1	1,1	1,1	1,1

Angles		Pole Height= 50 Ft							
Shortest lead length	Angle=	5	10	15	20	30	40	50	60
5		1,1	1,1	1,1	1,1	1,1	1,1	2,1	2,1
10		1,1	1,1	1,1	1,1	1,1	1,1	1,1	1,1
15		1,1	1,1	1,1	1,1	1,1	1,1	1,1	1,1
20		1,1	1,1	1,1	1,1	1,1	1,1	1,1	1,1
25		1,1	1,1	1,1	1,1	1,1	1,1	1,1	1,1
35		1,1	1,1	1,1	1,1	1,1	1,1	1,1	1,1

Angles		Pole Height= 55 Ft							
Shortest lead length	Angle=	5	10	15	20	30	40	50	60
5		1,1	1,1	1,1	1,1	1,1	1,1	2,1	2,1
10		1,1	1,1	1,1	1,1	1,1	1,1	1,1	1,1
15		1,1	1,1	1,1	1,1	1,1	1,1	1,1	1,1
20		1,1	1,1	1,1	1,1	1,1	1,1	1,1	1,1
25		1,1	1,1	1,1	1,1	1,1	1,1	1,1	1,1
35		1,1	1,1	1,1	1,1	1,1	1,1	1,1	1,1

Output information is in the format of <# of down guys>, <# of anchors>. Minimum guy spacing is 5'.

## GUY AND ANCHOR ASSEMBLY STRENGTH SUMMARY

PUD1
05/02/25

Hardware Description	Manufacturer Name	Part #	Ultimate Strength (lbs.)	Grade B Strength Factor	Grade B Working Strength (lbs.)	Grade C Strength Factor	Grade C Working Strength (lbs.)
<b>Guy working strength</b>							
Pole eye			21,000	0.65	13650	0.85	17850
(2) Washer, Curved 4"x4"			28,400	0.80	22720	0.80	22720
(2) Bolt, 3/4"			18,350	0.65	<b>11927.5</b>	0.85	<b>15597.5</b>
18M			18,000	0.9	16200	0.9	16200
Insulator, Fiberglass, 2 Wheel, 7'			21,000	1	21000	1	21000
Automatic Deadend			18,000	0.9	16200	0.9	16200
Prefomed Deadend			18,000	0.9	16200	0.9	16200
<b>Anchor working strength</b>							
Anchor Rod, 1"			36,000	1	36000	1	36000
Cross Plate Anchor Rod, 1-1/4"			56,000	1	56000	1	56000
10" single Helix Screw Anchor installed at 3000 ft-lb torque			21,200	1	<b>21200</b>	1	<b>21200</b>
14" single Helix Screw Anchor installed at 3000 ft-lb torque			24,100	1	24100	1	24100
24" Cross Plate Anchor (class 5 soil assumed)			26,500	1	26500	1	26500

# SCOPE

This section covers selection of down guys, span guys, sidewalk guys, push braces and anchors. The selections are based upon wood strengths, guy component strengths, anchor strengths and soil holding power of anchors.

## DEFINITIONS (Taken from The Lineman's and Cableman's Handbook, Seventh Edition)

### 1. Down Guy-

Consists of a wire running from the attachment near the top of the pole to a rod and anchor installed in the ground.

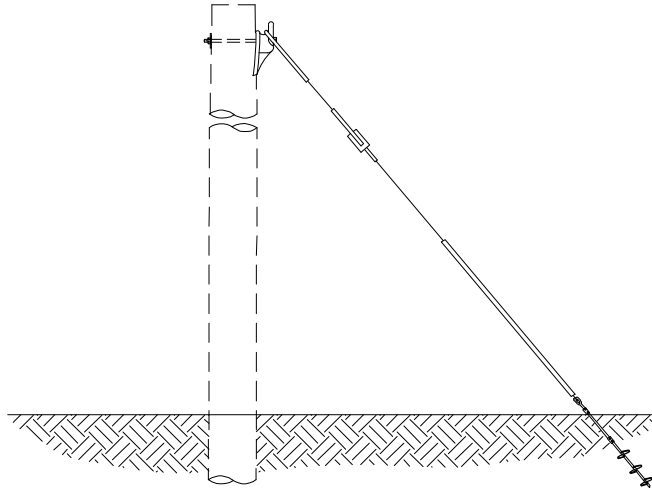

### 2. Span Guy-

Consists of a guy wire installed from the top of a pole to the top of an adjacent pole to remove the strain from the line conductors.

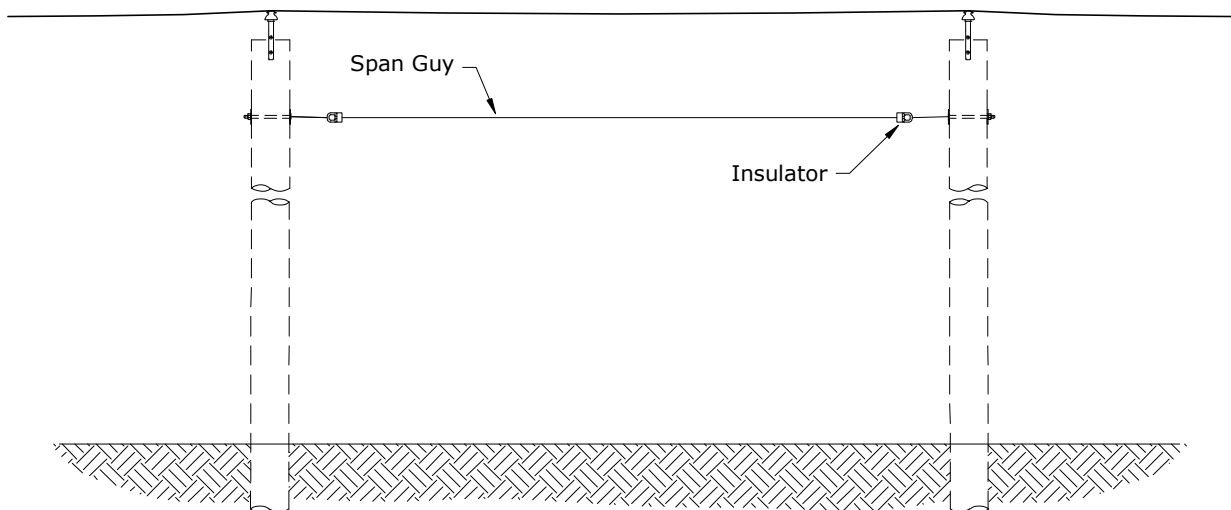

Rev 2: Added definitions and updated to 2007 NESC.

		<b>CONSTRUCTION STANDARDS</b>		△
		GUY & ANCHOR SELECTION		
PAGE: 1 of 7		<b>G</b>		△

### 3. Head Guy-

A guy wire running from the top of a pole to a point below the top of the adjacent pole.

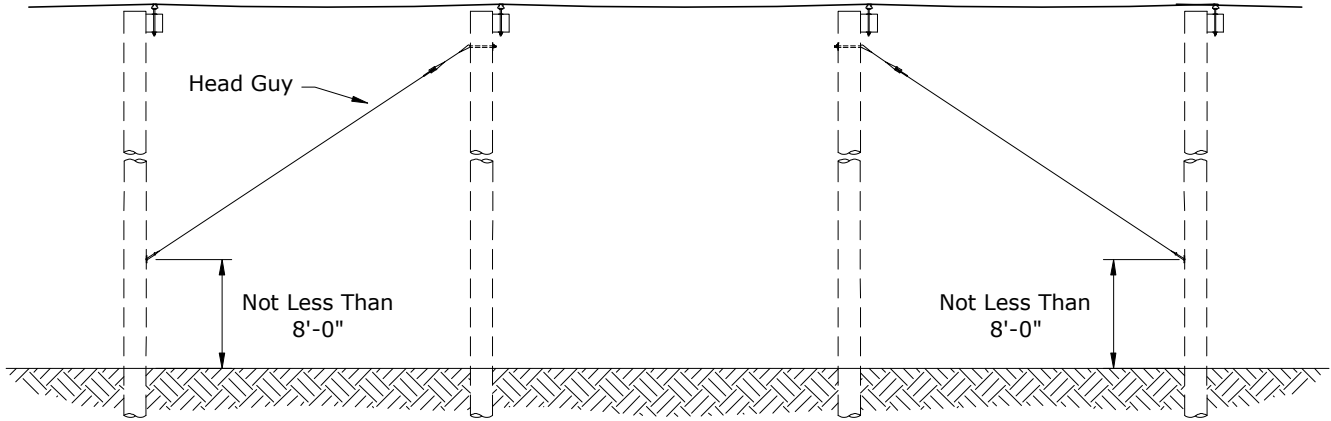

### 4. Guy Stub-

A guy wire installed between a line pole and a stub pole. The span guy, guy stub pole, and the down guy make up the guy stub.

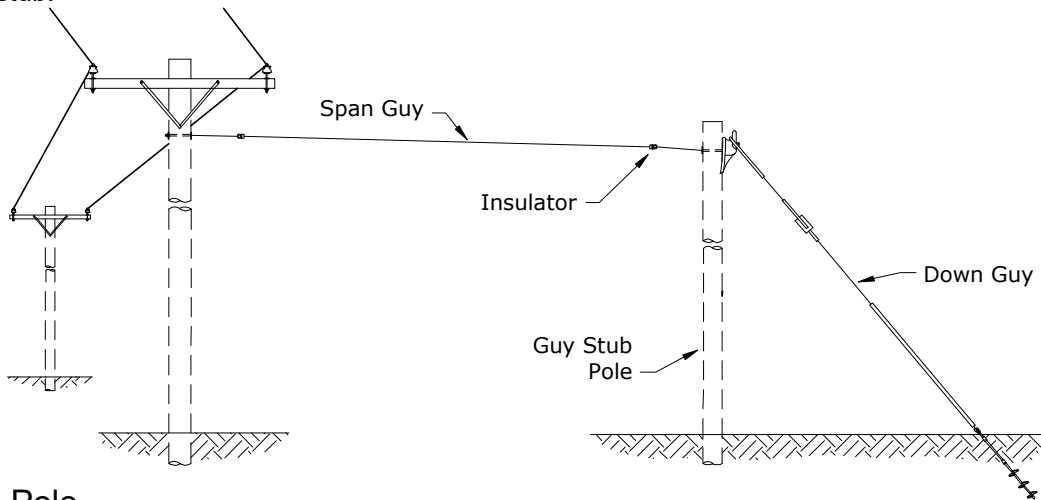

### 5. Push Pole-

A pole used as a brace to a line pole.

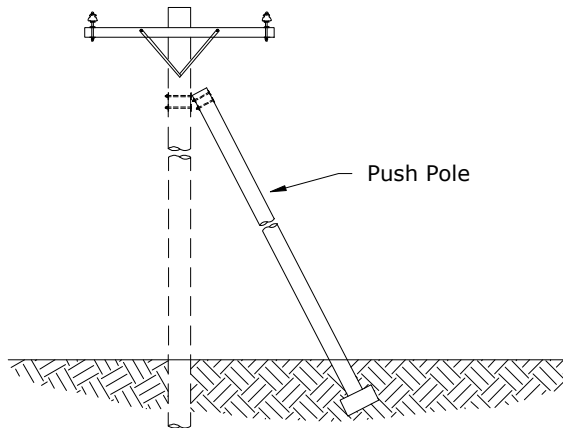

## CONSTRUCTION STANDARDS

### GUY & ANCHOR SELECTION

PAGE:  
2 of 7

**G**

CAD FILE:

REVISIONS			
DATE	ENGR	OPS	
APP:		SECTION	
DATE:			

# GENERAL

## 1. Guying

a) Guying assemblies include down, span and sidewalk types. A push brace consisting of a pole and attachment fittings may be used in place of tensioned wire guying only where tension guying is impossible by reason of location or rights-of-way.

b) Guying requirements can often be advantageously combined on a deadend pole, a span or more away by extending the circuit or by use of span guys in order to provide a reduced combined guying load on the same pole. A sidewalk guy is an expensive method of guying and provides limited support, particularly on taller poles, due to the comparatively short guy lead. DO NOT use a sidewalk guy if a down or span guy is possible.

c) Guy assemblies are designed for the maximum allowable load which may be supported by the pole and the related hardware. Heavy duty guying will normally require the use of multiple guying attachments.

d) A guy marker shall be used on all down guy and sidewalk guy locations. A minimum of one marker per anchor is required. It should be noted that guy markers DO NOT PROTECT OR "GUARD" a down/sidewalk guy, but rather warn the public of its presence.

## 2. Sidewalk Guy Insulation

Sidewalk guys shall have guy insulators installed in the guy strand above the horizontal guy strut. The breakers should be at a point that will allow at least 6" clearance between the breaker and the strut attachment to the pole, should the guy wire become broken.

## 3. Grounded Guys

Grounded guys shall not be used. All guys on transmission and distribution circuits shall have insulation sections (Johnny balls or fiberglass rods) installed on all new and rebuilt circuits. Grounded guys are to be replaced by insulated guys when work is done on that pole.

## 4. Application of Guy Insulators



It is impractical to show every NESC requirement for applying guy strain insulators. A clear understanding of the rules will provide for the correct applications. These guidelines will help in understanding the requirements.

Guideline 1 (see figure #1) - All down guys shall have a minimum of one guy insulator. (NESC 215C2)

Guideline 2 - All span guys will have a minimum of two guy insulators. (NESC 215C5)

Guideline 3 (see figure #2) - On jointly used poles, down guys that pass within 12 inches of supply conductors, and also pass within 12 inches of communication cables, shall be insulated with a guy insulator at a point below the lowest supply conductor and above the highest communication cable. (NESC 235I)

Guideline 4 (see figure #1) - All guy insulators shall be located at least 8 feet above the ground including when the guy would sag or break. (NESC 215C5a)

	<b>CONSTRUCTION STANDARDS</b>		REVISIONS			
				DATE	ENGR	OPS
						
PAGE: 3 of 7	<b>G</b>		CAD FILE:	APP:	SECTION	
				DATE:		

**Guideline 5** (see figure #1) - Guy insulators shall be placed so that in case any guy wire contacts, or is contacted by an energized conductor or part, the voltage will not be transferred to other facilities on the structure. (NESC 215C5b)

**Guideline 6** (see figure #3) - Guys may sag or break, bringing them into contact with energized conductors, jumpers, or bushings to create a hazard to the public. Guy insulators shall be placed so that when any guy sags down or falls upon another facility, the insulators will remain effective. (NESC 215C5c)

Figure 1: Guidelines 1, 4, 5, and 6

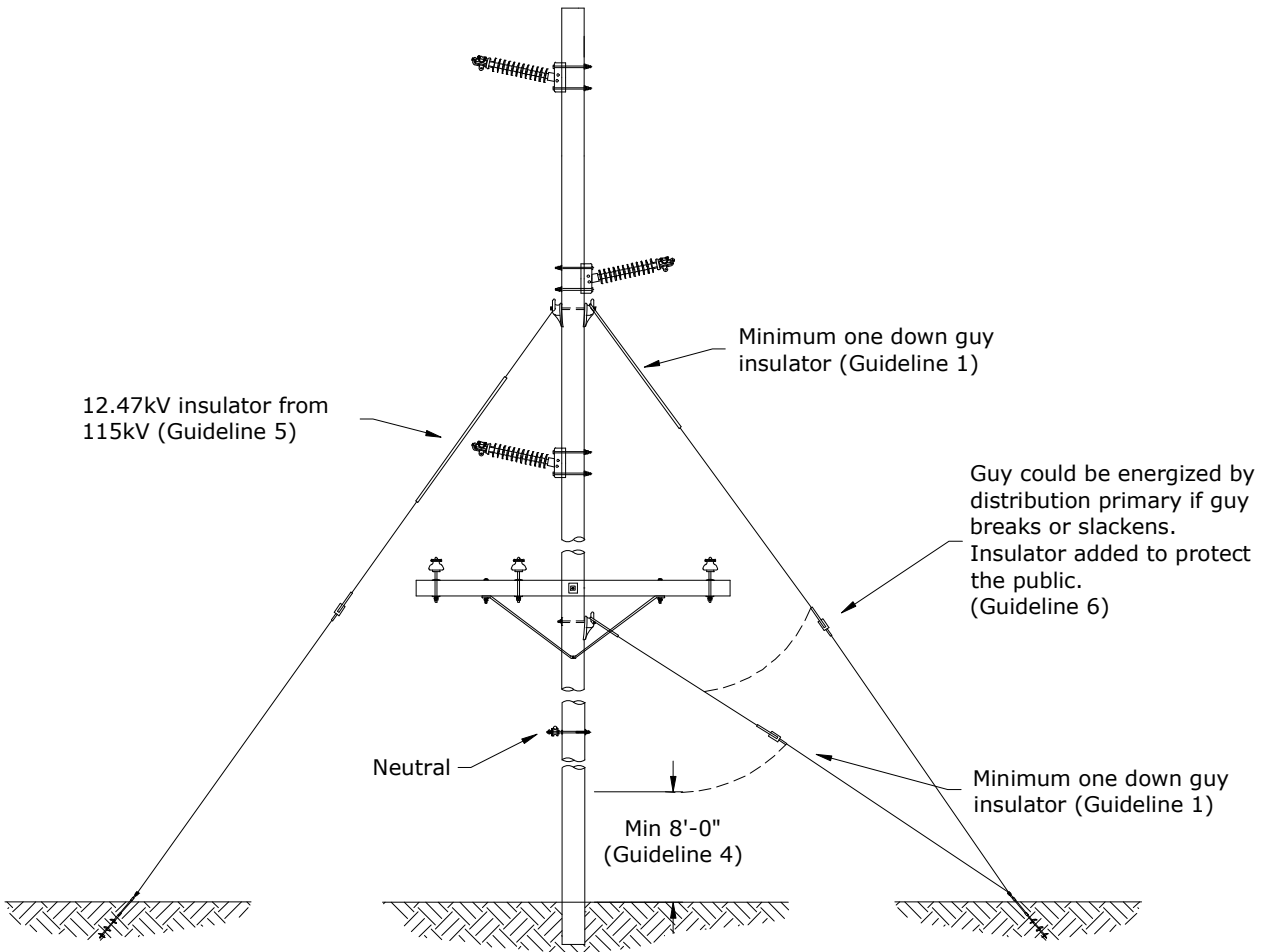

# CONSTRUCTION STANDARDS

## GUY & ANCHOR SELECTION

### REVISIONS

△	DATE	ENGR	OPS

Figure 2: Guying near communication cable (Guideline 3)

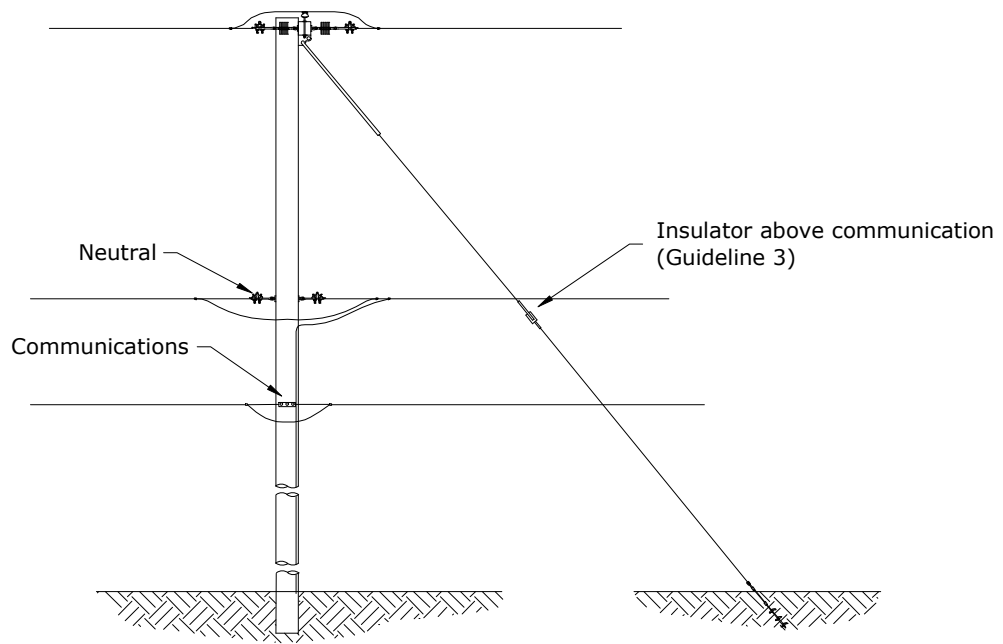
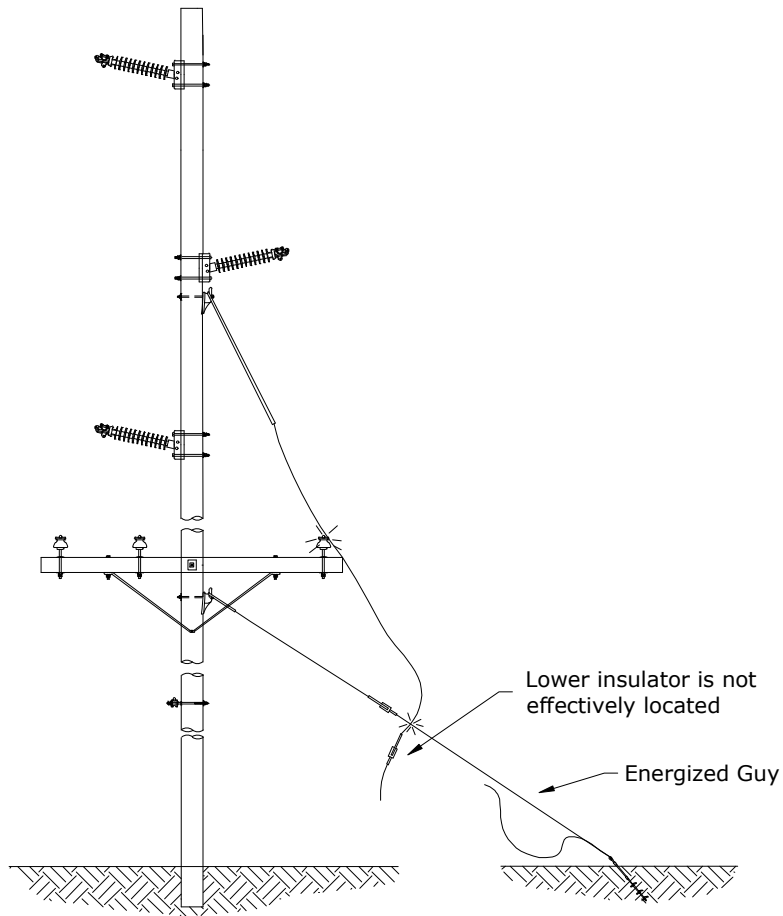

Figure 3: Allow for guys to sag or break (Guideline 6)



# CONSTRUCTION STANDARDS

## GUY & ANCHOR SELECTION

PAGE:  
5 of 7

**G**

CAD FILE:

REVISIONS			
△	DATE	ENGR	OPS
△			
APP:	SECTION		
DATE:			

## 5. Anchors

Anchors shall be located so as to provide as large a lead over height ratio with as little interference to the public as possible.

### **ANCHOR SELECTION**

#### 1. Anchor Selection in General

- a. Anchor selection is based upon guy tension, type of soil, available installation equipment and location.
- b. Power installed screw anchors are the best choice if soil and location permit their use.
- c. A plate anchor may be used if a hole can be dug either by machine or blasting or hand dug at inaccessible locations.
- d. If solid rock is encountered, specify one of the rock anchors.
- e. Some swamp areas cannot be covered by these anchors and must have special design consideration.

#### 2. Soil Classification

The table of soil classification data which follows is for general use in specifying anchors.

SOIL CLASSIFICATION DATA			
CLASS	PROBE VALUE	COMMON SOIL-TYPE DESCRIPTION	GEOLOGICAL SOIL CLASSIFICATION
0		Sound hard rock, unweathered	Granite, Basalt, Massive Limestone
1	750-1600 in-lbs	Very dense and/or cemented sands; coarse gravel and cobbles	Caliche, (nitrate-bearing gravel/rock)
2	600-750 in-lbs	Dense fine sand; very hard silts and clays (may be preloaded)	Basal Till; Boulder Clay; Caliche; Weathered Laminated Rock
3	500-600 in-lbs	Dense sands and gravel; hard silts and clays	Glacial Till; Weathered Shales, Schist, Gneiss and Siltstone
4	400-500 in-lbs	Medium dense sand and gravel; very stiff to hard silts and clays	Glacial Till, Hardpan and Marls
5	300-400 in-lbs	Medium dense coarse sands and sandy gravels; stiff to very stiff silts and clays	Saprolites, Residual Soils
6	200-300 in-lbs	Loose to medium dense fine to coarse sands to stiff clays and silts	Dense Hydraulic Fill; Compacted Fill; Residual Soils
7	100-200 in-lbs	Loose fine sand; alluvium; loess; medium-stiff and varied clays; fill	Flood Plain Soils; Lake Clays; Adobe; Gumbo, Fill
8	< 100 in-lbs	Peat, organic silts; inundated silts, fly ash, very loose sands, very soft to soft clays	Miscellaneous Fill, Swamp Marsh

		<b>CONSTRUCTION STANDARDS</b>		REVISIONS					
				△	DATE	ENGR	OPS		
		GUY & ANCHOR SELECTION							
PAGE: 6 of 7		<b>G</b>		CAD FILE:		APP:		SECTION	
				DATE:					

# CONVERTING HYDRAULIC PRESSURE TO TORQUE

If a shear pin torque indicator is not going to be used, the operator can make a conversion chart so that pounds per square inch of system hydraulic pressure can be converted to torque at the anchor. This chart can be made by temporarily using a shear pin torque indicator and recording maximum hydraulic pressure readings when various numbers of pins shear. Each pin is equal to 500 ft-lb of torque. After the conversion chart is completed, it is not necessary to use the shear pin torque indicator. Any changes in the hydraulic motor system will require a new conversion chart. Check the accuracy of the chart annually, after any hydraulic system repairs, or before critical anchor installation such as mainline, distribution lines, or transmission lines.

TRUCK # _____		CHART DATE _____	OPERATOR _____
SYSTEM HYDRAULIC PRESSURE LBS./SQ. IN.	TORQUE IN FT. LBS	NUMBER OF SHEARED PINS	NOTES
	500	1	
	1000	2	
	1500	3	
	2000	4	
	2500	5	
	3000	6	
	3500	7	
	4000	8	
	4500	9	
	5000	10	
	5500	11	
	6000	12	
	6500	13	
	7000	14	

	<b>CONSTRUCTION STANDARDS</b>		REVISIONS			
	GUY & ANCHOR SELECTION		△	DATE	ENGR	OPS
	PAGE:		CAD FILE:		SECTION	
	7 of 7	<b>G</b>	APP:		DATE:	

## Grounding Installations - Distribution Circuits

**The minimum requirements for grounding assemblies are specified in the National Electrical Safety Code (IEEE C2-2017).**

Rule #93-A: Copper-clad steel ground without joint or splice, if possible, free from sharp bends and as short as possible.

Rule #93-C-2: Ground for AC distribution shall have not less than 1/5 of the line conductance. (#4 Cu-equivalent copper-clad steel).

Rule #94-B: Driven electrodes, if practicable, shall be below permanent moisture level, minimum size 5/8" x 8', driven eight (8) feet deep. When rod cannot be driven eight (8) feet deep, install second rod on opposite side of pole and interconnect ground wire. The top of the ground rod shall be flush with or below the ground level unless suitably protected.

Rule #97-A: Ground conductors shall be run separately to ground for:

- Surge Arresters over 750v and frames of any equipment operating over 750v (see exceptions below).
- Lighting and power circuits under 750v.
- Shield wires of power circuits

Rule #97-B: An interconnection of primary surge arrester ground and primary and secondary neutral is permitted on a multi-grounded system. This solid interconnection shall be made since surge current is routed through several parallel ground impedances and the danger of insulation damage no longer exists even under conditions of high surge current and high ground impedance.

Rule #215-C: Non-current-carrying parts shall be grounded unless they are 8 feet or more above readily accessible surfaces or they are otherwise isolated or guarded.

<h3 style="margin: 0;">CONSTRUCTION STANDARDS</h3> <p style="margin: 0;">INSTALLATION OF GROUNDING ASSEMBLIES</p>		REVISIONS		
			DATE	ENGR
PAGE: 1 of 1		N		CAD FILE:
		APP:	SECTION	
		DATE:		

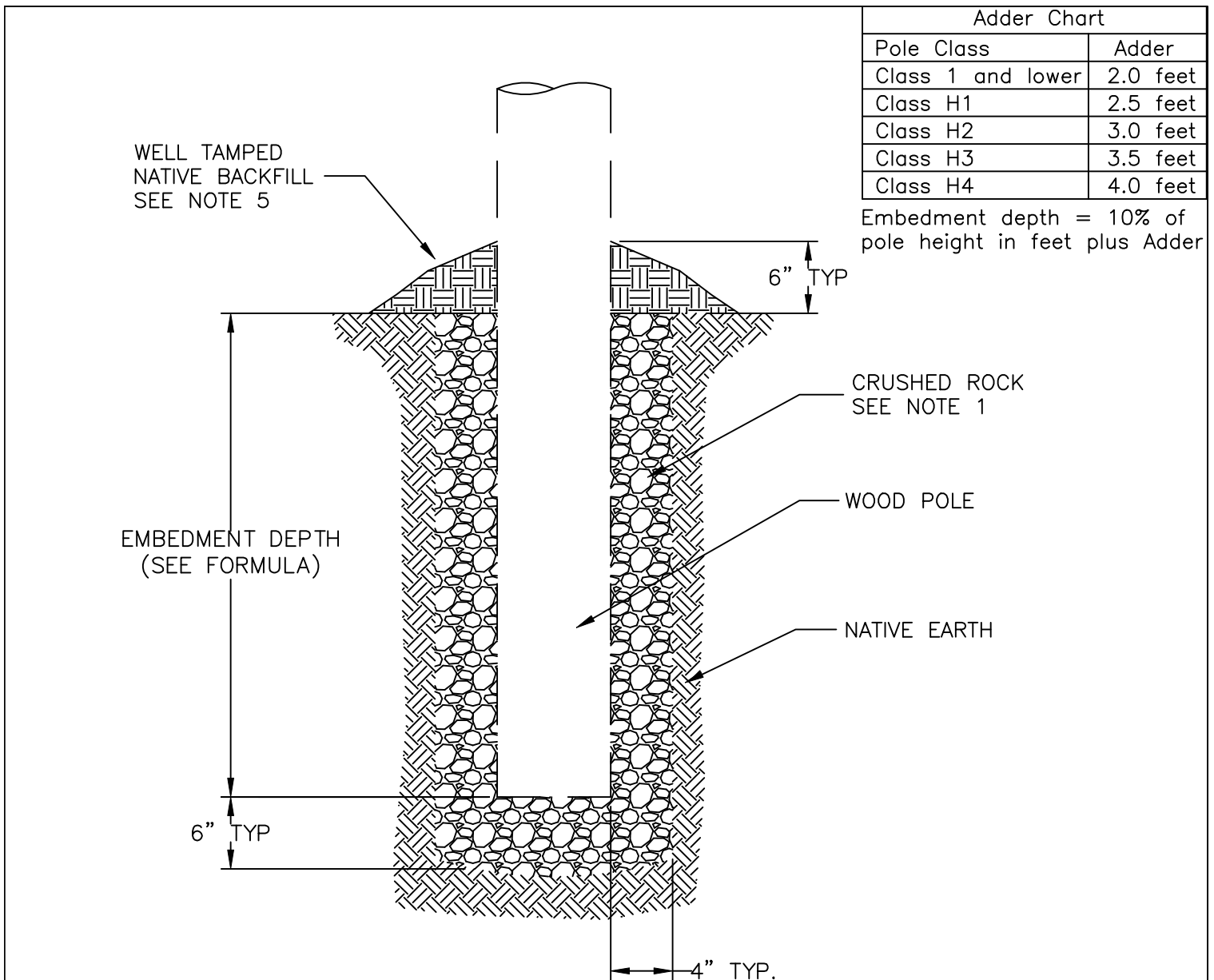

Adder Chart	
Pole Class	Adder
Class 1 and lower	2.0 feet
Class H1	2.5 feet
Class H2	3.0 feet
Class H3	3.5 feet
Class H4	4.0 feet

Embedment depth = 10% of pole height in feet plus Adder

**NOTES:**

1. CRUSHED ROCK BACKFILL: 3/4-INCH MINUS WITH SUFFICIENT FINES FOR PROPER COMPACTION. IN AREAS WHERE SMALLER FINES ARE AVAILABLE AT COMPARABLE COST, THE USE OF SMALLER FINES IS RECOMMENDED. BACKFILL SHALL BE FREE OF ROOTS, CLAY BALLS AND ORGANIC MATERIALS.
2. BACKFILL SHALL BE PLACED IN 6-IN LIFTS AND PNEUMATICALLY TAMPED.
3. IT SHALL BE CONTRACTOR'S RESPONSIBILITY TO DETERMINE IF CASING IS REQUIRED FOR HOLE EXCAVATION. IF CASING IS REQUIRED, THE CONTRACTOR SHALL PROVIDE CASING AT NO EXTRA COST.
4. WELL TAMPED NATIVE BACKFILL SHALL BE PLACED AT GRADE AROUND THE POLE AS SHOWN.

<p><b>CONSTRUCTION STANDARD</b></p> <p><b>POLE HOLE DEPTH</b></p> <p><b>AND BACKFILL</b></p> <p><b>REQUIREMENTS</b></p> <p><b>TM-10-MA01</b></p> <p><b>SHEET 1 OF 1</b></p>	DATE	REVISION
	7/20/15	0
DESIGN BY: ADB	DRAWN BY: ADB	
APPROVED BY: <u>MHK</u>	Drawing No.	
DATE: 06/29/15	TM-10-MA01	

# OVERHEAD TRANSFORMER

## FUSE LOOK-UP TABLE

OH XFMR	K-LINK
15	6K
25	6K
37.5	8K
50	10K
75	15K
100	20K

\*\*\* HOA to provide the WAC required minimum vertical clearance.

468-34-290 Vertical clearance.

The vertical clearance for overhead power and communication lines above the highway and the lateral and vertical clearance from bridges shall conform with the National Electrical Safety Code and/or with the clearances as shown below, whichever is greater.

TYPE OF UTILITY LINE LINES	CROSSING ROADWAYS	LONGITUDINAL
Communications and Cable Television	24'	20'
Communications and/or Cable Television joint usage with electrical	20'	20'
ELECTRICAL		
0 - 750 volts	24'	24'
751 - 15,000 volts	30'	27'
15,001 - 50,000 volts	32'	32'
50,001 volts and over	34'	32'

- (1) The minimum height of highway crossing shall be measured from the point of the roadway directly under the crossing.
- (2) The minimum height of longitudinal lines shall be measured from ground line.
- (3) All clearances shall be at State Electrical Construction Code temperature and loading standards, and comply with all other requirements of this code.

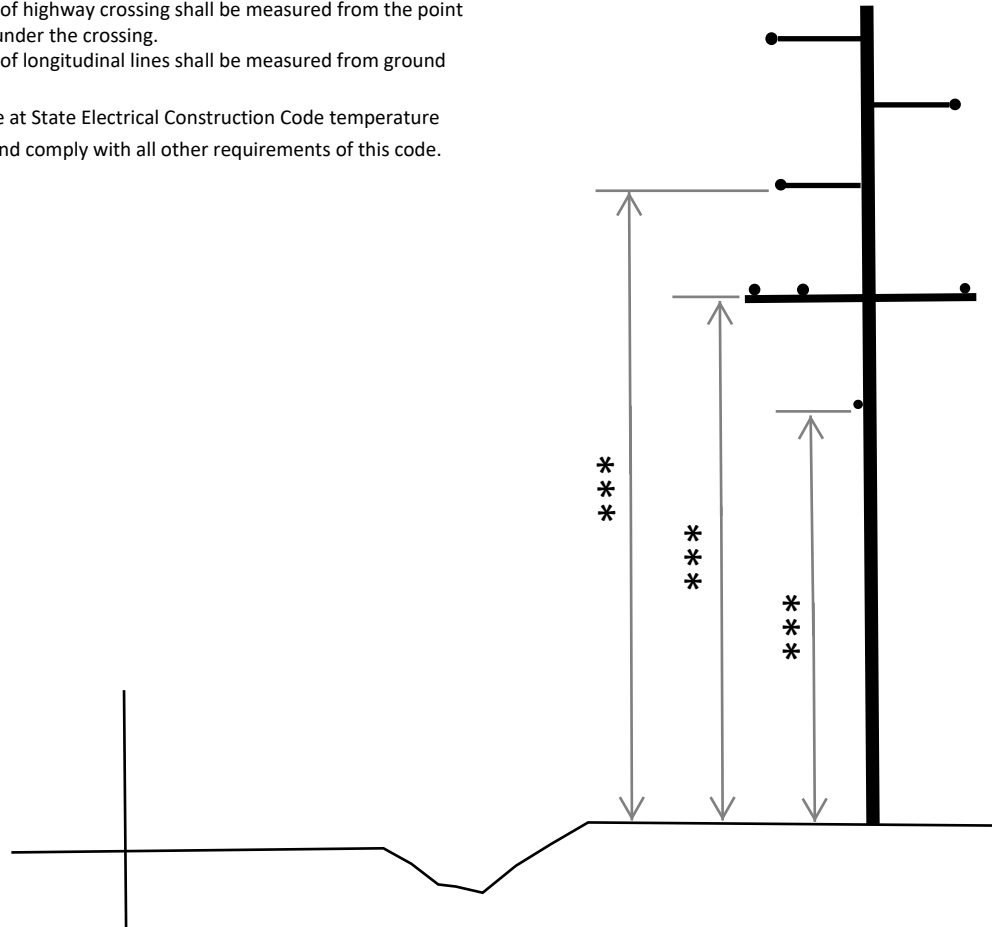

Minimum Vertical Clearance Requirements

# STANDOFF BRACKET PLACEMENT

- 1) Basic Rule: On poles without anchors or existing clean poles, 1Ø primary and secondary riser brackets should be installed on the "belly button" side of the pole. Typically, a transformer would also be installed on the "belly button" side above the 1Ø primary or secondary riser.
- 2) On poles with an existing transformer or transformer bank, the bracket should be installed under the transformer or center transformer on a bank with the alternative position being 45°-90° away from street side. If the existing transformer is located on the opposite side of the "belly button," place the bracket under the transformer.
- 3) Standoffs are typically not installed under guy wires no matter where the "belly button" is located.
- 4) Standoffs and risers should be placed to avoid conflict with overhead communication wires and guy wires.
- 5) For poles with an existing riser, use the brackets that are installed to maintain climbing space.

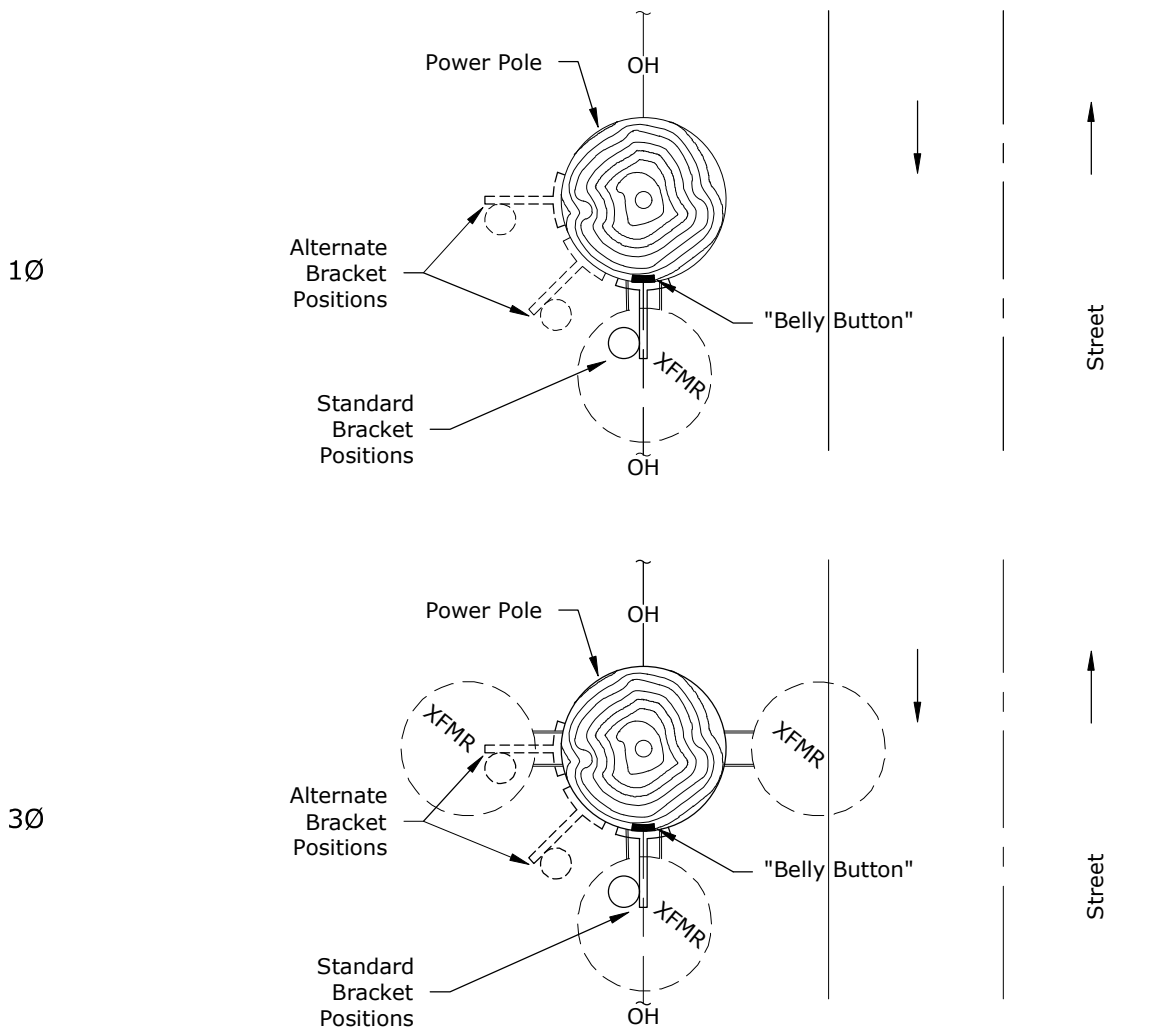

## CONSTRUCTION STANDARDS

### 1Ø PRIMARY (U1) & SECONDARY (U8) RISER GUIDELINES

REVISIONS			
Δ	DATE	ENGR	OPS

PAGE:  
1 of 1

# U10

CAD FILE:

APP:  
DATE:

SECTION

ALL CONDUIT SHALL BE GRAY ELECTRICAL CONDUIT AND SHALL BE UL LISTED AND NEMA TC-2 OR TC-3 LABELED -- NO OTHER PIPE IS ACCEPTABLE.

1. All primary and secondary cables shall be in conduit.
2. All road and street crossings shall be in schedule 40, PVC, gray electrical conduit or polyethylene of equal or greater strength specifications. Pipe with other designated use is not acceptable.
3. All risers above finished grade shall be in schedule 80 PVC.
4. Acceptable conduit sizes are as follows:
  - 1-PH #2 primary cable in 1-2" conduit
  - Triplex secondary cable in 1-3" conduit
  - 3-PH 500MCM primary cable in 3-3" conduits
5. Where rock is encountered and the depths shown on D1.1 cannot be accomplished, a lesser depth with schedule 80 conduit\* and/or control density fill (CDF) may be approved.\* Contact Mason PUD #1 Engineering.
6. All conduit terminations shall have end bells or bushings.
7. All conduits that terminate into energized enclosures shall be installed by qualified personnel with a Mason PUD #1 standby person.
8. All conduit runs shall be designed to limit pulling tension to the values specified on UCP1.
9. All conduit ends shall be chamfered 45° x 1/4" internally at all straight ends (not belled ends).
10. All conduits installed for future use shall be marked with 3M electrical markers within six inches at both ends. All ends shall be elbowed up. The elbow shall NOT be glued to the conduit.
11. Sufficient select backfill shall be placed to prevent crushing of the conduits due to trucks and other heavy equipment.
12. Unused conduits shall have removable plugs designed for that purpose in both ends.
13. Road and street crossings may be either trenched and backfilled, bored or pushed whichever is acceptable to the governing agency.
14. All street and road crossings shall be at property lines.
15. Where conduit bends are required, they shall meet the requirements for cable pulling in the construction specifications. Only manufactured radii are acceptable. No heated bends.
16. A condulet (LB) shall never be used.
17. Conduit sweeps shall be 24" secondary\* and 36" primary radius.
18. Conduits installed for futures should be plumbed into transformer with elbows and capped. Flex pipe is not acceptable.
19. Conduits shall be installed so that cable is pulled toward the end bells to avoid scraping cable on sharp edges of conduit.
20. All cut ends of conduits shall be square.
21. Steel mandrels shall be pulled through the conduits to detect damage and debris.

## CONSTRUCTION STANDARDS

### CONDUIT REQUIREMENTS

REVISIONS			
△	DATE	ENGR	OPS
△ REVISIONS MARKED WITH STAR			
APP:		SECTION	
DATE:			

PAGE:  
1 of 1

# UC1

CAD FILE:

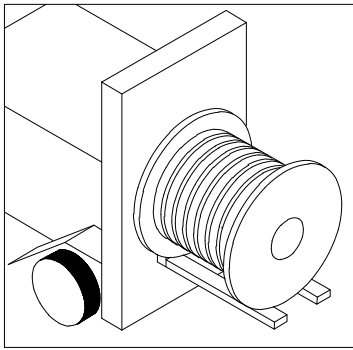

CRADLE BOTH REEL FLANGES BETWEEN FORKS.

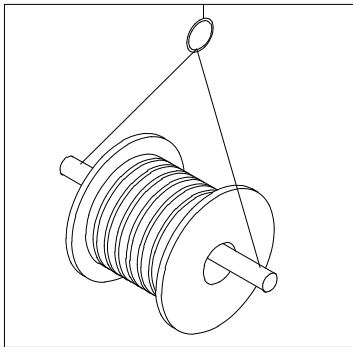

REELS CAN BE HOISTED WITH A SHAFT EXTENDING THROUGH BOTH FLANGES.

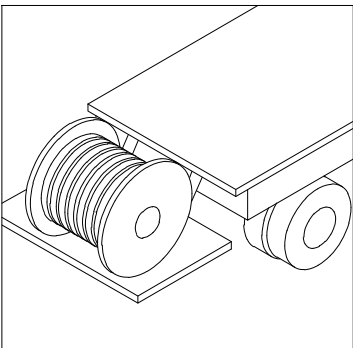

LOWER REELS FROM TRUCK USING HYDRAULIC GATE, HOIST OR FORK LIFT. (LOWER CAREFULLY)

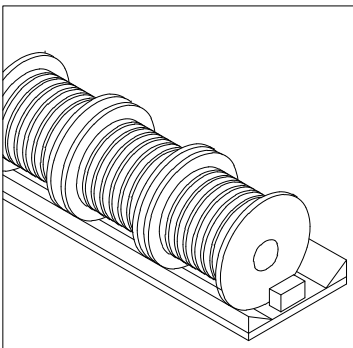

ALWAYS LOAD WITH FLANGES ON EDGE AND CHOCK AND BLOCK SECURELY.

# HOW TO HANDLE CABLE REELS

← YES

NO →

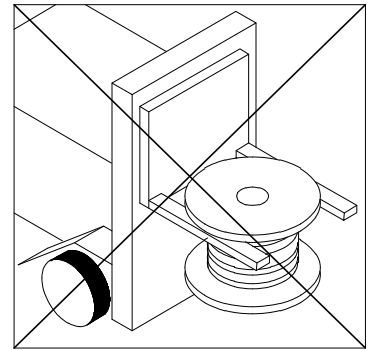

DO NOT LIFT BY TOP FLANGE. CABLE OR REEL WILL BE DAMAGED.

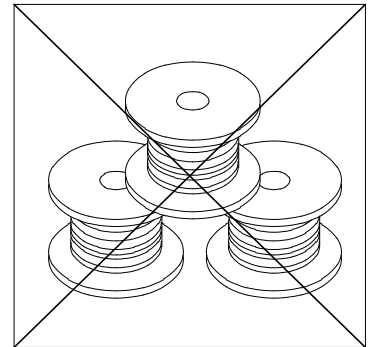

UPENDED HEAVY REELS WILL OFTEN ARRIVE DAMAGED. REFUSE OR RECEIVE SUBJECT TO INSPECTION FOR HIDDEN DAMAGE.

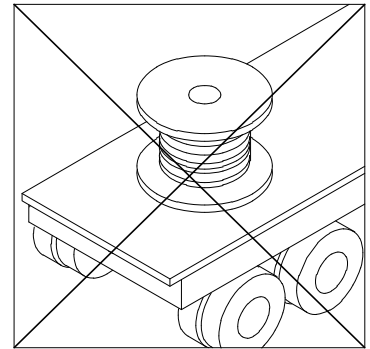

DO NOT UPEND REELS

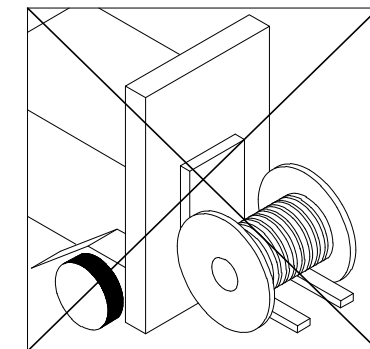

NEVER ALLOW FORKS TO TOUCH CABLE SURFACE OR REEL WRAP.

## CONSTRUCTION STANDARDS

### UNDERGROUND CABLE REEL HANDLING

#### REVISIONS

Δ	DATE	ENGR	OPS

Δ	APP:	SECTION
	DATE:	

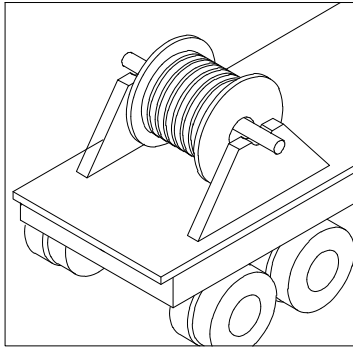

REELS GOING TO JOBS SHALL ALWAYS BE MOUNTED ON A HORIZONTAL AXLE.

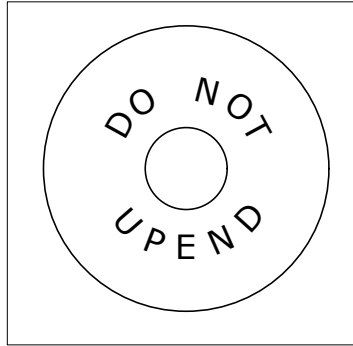

THIS SIGN APPLIES FOR ANY REEL HANDLING. NOT JUST FACTORY DELIVERY.

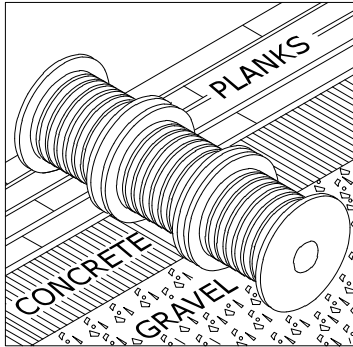

ALWAYS STORE REELS ON A HARD SURFACE.

# HOW TO HANDLE CABLE REELS

← YES

NO →

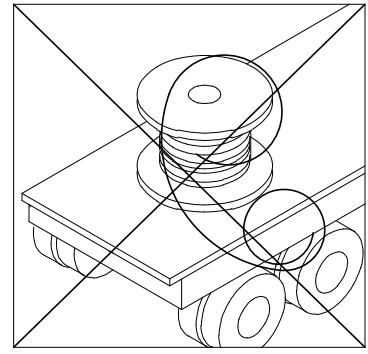

NEVER REMOVE CABLE FROM A REEL THIS WAY. IT WILL KINK.

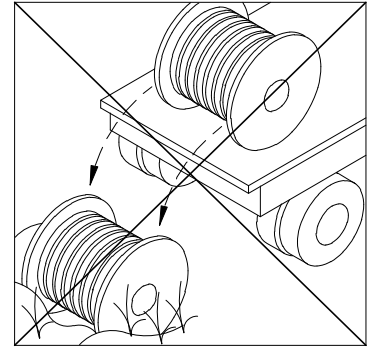

NEVER DROP A CABLE REEL FROM ANY HEIGHT WITH EVEN A SMALL AMOUNT OF CABLE ON THE REEL.

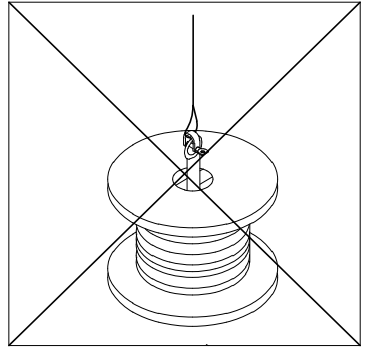

NEVER USE A SWIVEL TO REMOVE CABLE FROM A REEL.

## CONSTRUCTION STANDARDS

### UNDERGROUND CABLE REEL HANDLING

PAGE:  
2 of 2

UCH-0

CAD FILE:

REVISIONS			
△	DATE	ENGR	OPS
△			
APP:	SECTION		
DATE:			

MOVEMENT, STORAGE, AND HANDLING OF CABLE

MOVEMENT OF REELS OF CABLE

1. REELS OF CABLE MUST NOT BE DROPPED FROM ANY HEIGHT, PARTICULARLY FROM TRUCKS OR OTHER TRANSPORTING EQUIPMENT.
2. LIFT REELS USING FOLLOWING METHODS:
  - A) CRANE OR BOOM TYPE EQUIPMENT--INSERT SHAFT (HEAVY ROD OR PIPE) THROUGH REEL HUBS AND LIFT WITH SLINGS ON SHAFT, PREFERABLY UTILIZING SPREADER OR YOKE TO REDUCE OR AVOID SLING PRESSURE AGAINST REEL HEAD.
  - B) FORK LIFT TYPE OF EQUIPMENT MAY BE USED TO MOVE SMALLER, NARROWER WIDTH REELS. FORK TINES SHALL BE PLACED SO THAT LIFT PRESSURE IS ON REEL HEADS, NOT ON CABLE, AND MUST REACH ALL THE WAY ACROSS REELS SO LIFT IS AGAINST BOTH REEL HEADS.
3. REELS MAY BE MOVED SHORT DISTANCES BY ROLLING. REELS SHOULD BE ROLLED IN THE DIRECTION INDICATED BY ARROWS PAINTED ON REEL HEADS. SURFACES OVER WHICH THE REELS ARE TO BE ROLLED SHALL BE FIRM, CLEAR OF DEBRIS, AND ALSO CLEAR OF PROTRUDING STONES, HUMPS, ETC. WHICH MIGHT DAMAGE THE CABLE IF THE REEL STRADDLED THEM.

STORAGE OF REELS OF CABLE

1. CABLE ENDS ARE SEALED PRIOR TO SHIPMENT, IF FACTORY SEALS ARE CUT OFF, NEW SEALS MUST BE APPLIED TO PREVENT MOISTURE ENTRY INTO CABLE.
2. WHENEVER POSSIBLE, THE FACTORY APPLIED PROTECTIVE COVER SHOULD BE LEFT IN PLACE UNTIL REMOVAL IS ABSOLUTELY NECESSARY. ADDITIONAL COVERING SUCH AS TARPAULIN, PLASTIC SHEETING, ETC., MAY BE USED IF CABLE IS TO BE STORED FOR LONG PERIODS OUTDOORS OR IN EXCESSIVELY DIRTY, DUSTY AREAS.
3. STORE REELS OF CABLE ON A FIRM SURFACE, PAVED IF POSSIBLE, OR ON PLANKING TO PREVENT SETTLING INTO SOFT GROUND.
4. THE STORAGE AREAS SHALL HAVE GOOD DRAINAGE.
5. USE FENCING OR OTHER BARRIERS TO PROTECT CABLES AND REELS AGAINST DAMAGE BY VEHICLES OR OTHER EQUIPMENT MOVING ABOUT IN THE STORAGE AREA.
6. NEVER STORE REELS ON END.

**CONSTRUCTION STANDARDS**

UNDERGROUND CABLE  
HANDLING & STORAGE

REVISIONS

	DATE	ENGR	OPS

	APP:	SECTION

PAGE:  
1 of 2

**UCH-1**

CAD FILE:

APP:  
DATE:

HANDLING DURING INSTALLATION



1. COLD WEATHER HANDLING AND PULLING-IN CABLE CAN BE MORE DIFFICULT, DEPENDING ON THE CABLE CONSTRUCTION AND INSTALLATION LOCATION. COLD-INDUCED STIFFNESS OF CABLE MUST BE CONSIDERED ALONG WITH RADIUS AND NUMBER OF BENDS IN THE PROPOSED INSTALLATION RUN.

IN GENERAL MOST CABLES CAN BE SAFELY HANDLED WITHOUT DAMAGE IF NOT SUBJECTED TO TEMPERATURE LOWER THAN 10°F (-12°C) IN THE 24 HOUR PERIOD PRECEDING PULLING AND BENDING. IF IT IS ANTICIPATED THAT STORE TEMPERATURES WILL BE BELOW THIS LEVEL DURING THE 24 HOUR PRE-PULL PERIOD, ARRANGEMENTS SHOULD BE MADE TO MOVE THE REEL, AVOIDING IMPACT, TO A WARMER AREA. IF NO INDOOR WARMING AREA IS AVAILABLE, A PLASTIC SHEETING-COVERED SHELTER MAY BE CONSTRUCTED AND HEATED. THE REEL SHOULD BE HELD IN THE WARM STORAGE AREA AT A TEMPERATURE OF AT LEAST 60°F (16°C) FOR 24 HOURS TO ENSURE TOTAL WARMUP. APPLY PULLING EYES OR GRIPS WHILE CABLE IS IN THE WARMING AREA, PRIOR TO MOVEMENT OUTDOORS OR UNCOVERING.

2. FACTORY APPLIED SEALS ON CABLE ENDS MAY BE DISRUPTED DURING THE PULLING OPERATIONS AND, THEREFORE, SHOULD BE CHECKED AND REPLACED IF THE CABLES ARE NOT GOING TO BE SPLICED OR TERMINATED RIGHT AFTER PULL-IN. THIS IS ESPECIALLY IMPORTANT FOR UNDERGROUND RUNS WHERE CABLE ENDS MAY BE LEFT IN ENCLOSURES WHICH ARE SUBJECT TO FLOODING.
3. THE CABLES SHOULD BE LAID INTO THE TRENCH BEING CAREFUL NOT TO TWIST OR KINK THEM. CARE SHOULD BE TAKEN NOT TO ABRASE OR IMPACT THE CABLE SURFACE AS IT LEAVES THE PAY-OFF EQUIPMENT AND ENTERS THE TRENCH. OVER-BENDING THE CABLE TO A POINT LESS THAN THE RECOMMENDED MINIMUM BENDING RADIUS ALSO SHALL BE AVOIDED. CABLES CAN BECOME EASILY OVER-BENT AT GUIDE POINTS SUCH AS SMALL SHEAVES OR ROLLERS LOCATED ON THE CABLE LAYING EQUIPMENT.

AFTER LAYING THE CABLES INTO THE TRENCH, THEY SHOULD BE COVERED WITH A LAYER OF SELECTED BACKFILL TO A LEVEL OF APPROXIMATELY THREE TO FOUR INCHES ABOVE THE CABLES' SURFACES. "SELECTED BACKFILL" IS DEFINED AS EITHER THERMAL SAND OR SAND-CLAY-GRAVEL MIXTURE CONTAINING SOME SMALL STONES NO GREATER IN SIZE THAN ONE-QUARTER TO ONE-HALF INCH ACROSS AT THEIR LARGEST DIMENSION.



**CONSTRUCTION STANDARDS**  
 UNDERGROUND CABLE  
 HANDLING & STORAGE

REVISIONS			
	DATE	ENGR	OPS
			
APP:	SECTION		
DATE:			

FOLLOWING ARE THE MINIMUM REQUIREMENTS FOR ANY CABLE PULL:

1. THE ENTIRE CONDUIT LENGTH INCLUDING BENDS AND RISERS SHALL BE CLEAN AND SMOOTH. THE TOTAL NUMBER OF ANGLES SHALL NOT EXCEED 270° \* WITHOUT PRIOR CPU ENGINEERING APPROVAL.
2. THE ENTIRE CONDUIT LENGTH INCLUDING BENDS AND RISERS SHALL BE SECURED IN THE FINAL LOCATION WITH ALL ACCESSORIES FIRMLY ATTACHED.
3. A PULLING TENSION CALCULATION SHALL BE COMPLETED TO ASSURE THAT MAXIMUM TENSION LIMITS WILL NOT BE EXCEEDED. SEE TABLE 1 FOR LIMITS.
4. SUFFICIENT APPROVED CABLE LUBRICANT SHALL BE USED AT THE START OF THE PULL.
5. THE CABLE SHALL NEVER BE BENT TO A RADIUS LESS THAN 12 TIMES THE CABLE DIAMETER. ALL SHEAVES SHALL HAVE A GROOVE DIAMETER OF NOT LESS THAN 24 TIMES THE CABLE DIAMETER.
6. NEVER ALLOW CABLE TENSION AT THE CABLE REELS. THE REELS SHALL BE TURNED BY HAND OR BY A POWER DEVICE SO THAT THE CABLE IS SLACK GOING INTO THE CONDUIT ENTRANCE.
7. LUBRICANT SHALL BE APPLIED TO THE CONDUIT BEFORE THE CABLE ENTERS THE CONDUIT. IT MAY BE POURED IN OR A PLASTIC BAG OF LUBRICANT MAY BE ATTACHED TO THE PULLING LINE AHEAD OF THE CABLE.
8. ALL CABLE ENDS SHALL BE SEALED TO PREVENT THE ENTRY OF MOISTURE OR DIRT.
9. FOR 1000 MCM CABLE, THE PULLING LINE SHALL BE 2500 LB, SEQUENTIALLY-NUMBERED, CONTINUOUS MULE TAPE.
10. CABLE ATTACHMENT MAY BE WITH KELLEMS (CABLE OR BASKET)\* GRIP OR CONDUCTOR (PULLING EYE) GRIP WHICHEVER THE PULLING TENSION CALCULATION DICTATES.
11. ALL CONDUIT ENTRANCES AND EXITS SHALL HAVE PROTECTIVE BUSHINGS IN PLACE THAT WILL ASSURE THAT CABLE DAMAGE DOES NOT OCCUR DURING THE PULL. AT RISER LOCATIONS, DO NOT GLUE PROTECTIVE BUSHING TO CONDUIT.
12. CABLE PULLING SPEED SHALL NOT EXCEED 50 FEET PER MINUTE.
13. ALL CABLE ENDS SHALL BE EITHER TERMINATED OR SEALED IMMEDIATELY AFTER THE PULL. NO CABLE ENDS SHALL BE LEFT EXPOSED OVER NIGHT OR DURING INCLEMENT WEATHER.

**CONSTRUCTION STANDARDS**  
 UNDERGROUND CABLE  
 PULLING REQUIREMENTS

REVISIONS			
	DATE	ENGR	OPS
			
APP:	SECTION		
DATE:			

PAGE:  
1 of 2

**UCP1**

CAD FILE:

14. IT SHALL BE THE RESPONSIBILITY OF THE DESIGNER TO AVOID UNFAVORABLE SIDEWALL PRESSURES. THE SIDEWALL PRESSURES SHALL BE CALCULATED USING THE FOLLOWING EQUATIONS:

(A.) THE SIDEWALL PRESSURE (P) IN GENERAL IS DEFINED AS THE TENSION OUT OF A BEND EXPRESSED IN POUNDS DIVIDED BY THE INSIDE RADIUS OF THE BEND EXPRESSED IN FEET. EQUATIONS 1A AND 1B ARE FOR THE "WORST CASE" CABLE.

EQ 1:  $P = \frac{T_0}{r}$  (ONE SINGLE CABLE)

1A:  $P = \frac{(3c - 2)}{3} \frac{T_0}{r}$  (TWO OR THREE SINGLE CABLES - CRADLE CONFIGURATION) WHERE  $c = 1 + \frac{4}{3} \left( \frac{d}{D - d} \right)^2$

1B:  $P = \frac{c T_0}{2r}$  (TRIANGULAR CONFIGURATION) WHERE  $c = \sqrt{1 - \left( \frac{d}{D - d} \right)^2}$

P = SIDEWALL PRESSURE, LBS PER FOOT OF RADIUS  
 T<sub>0</sub> = TENSION (LEAVING THE BEND), POUNDS  
 c = WEIGHT CORRECTION FACTOR (EQ. 7 AND 8)  
 r = INSIDE RADIUS OF CONDUIT IN FEET  
 d = CABLE O.D. IN INCHES  
 D = CONDUIT I.D. IN INCHES

THE MAXIMUM SIDEWALL PRESSURE SHALL NOT EXCEED 500 LB/FT FOR 1 CABLE OR 1000 LB/FT FOR 2 OR 3 CABLES.

TABLE 1 CABLE PULLING LINE TENSION LIMITS		
CABLE	KELLEMS (BASKET) GRIP TENSION (POUNDS)	CONDUCTOR (PULLING EYE) GRIP TENSION (POUNDS)
1 - 1/0 PRIMARY	845 *	845
2 - 1/0 PRIMARY	845 *	845 *
3 - 1/0 PRIMARY	1690 *	1690
1 - 1000 MCM PRIMARY	1000	5000 *
2 - 1000 MCM PRIMARY	1000 *	5000 *
3 - 1000 MCM PRIMARY	2000	5000 *
4/0 - 4/0 - 2/0 SEC.	3000 *	4450
350 - 350 - 4/0 SEC.	3000 *	5000 *

KELLEMS GRIP IS OVER THE CABLE JACKET. ALSO CALLED "CABLE GRIP" OR "BASKET GRIP." \*

NOTE: 5000 LB LIMIT DUE TO EQUIPMENT LIMITS.

\*

	<b>CONSTRUCTION STANDARDS</b> UNDERGROUND CABLE PULLING REQUIREMENTS		REVISIONS			
			△	DATE	ENGR	OPS
	PAGE: 2 of 2	<b>UCP1</b>	CAD FILE:	APP: DATE:	SECTION	

# Cable Pull Calculation

Date: 4/2/2026

Project name: LILLIWAUP CORNER      Work Order#: 25060

From location: P1      To location: V1

User input	Error Alerts:
wire size: <input type="text" value="500kCM EPR 133%"/> # of conductors: <input type="text" value="1"/> conduit size (in): <input 40="" hdpe"="" or="" pvc="" sch="" type="text" value="3"/> Lube: <input type="text" value="Yes"/> Reel Tension (lbs): <input type="text" value="50"/> Grip Type: <input type="text" value="Eye"/>	Weight/ft (W): 1.745      Pattern: NA Weight Correction (C): 1.00      Jam ratio: NA Wire diameter (d): 1.74      Max Tension(lbs): 4000 Conduit inner dia. (D): 3.042      Conduit fill(%): 32.72 Friction (F): 0.35      Conductor kcmil: 500.0

## Forward pull (percent of max tension: 51.1%)

sec	Section Type:	Bend type:	Radius(ft):	Angle (deg.):	Tension (lbs):	Sidewall Pressure (lbs):	Allowable Sidewall Pressure (lbs):
sec 1	<input type="text" value="Bend"/>	<input type="text" value="Vert. Up"/>	<input type="text" value="3"/>	<input type="text" value="90"/>	96	34	900
sec 2	<input type="text" value="Straight"/>		Dist (ft): <input type="text" value="50"/>	Angle (deg.): Up(+) Down(-) <input type="text" value="0"/>	127		
sec 3	<input type="text" value="Bend"/>	<input type="text" value="Vert. Down"/>	<input type="text" value="3"/>	<input type="text" value="45"/>	167	58	900
sec 4	<input type="text" value="Straight"/>		Dist (ft): <input type="text" value="800"/>	Angle (deg.): Up(+) Down(-) <input type="text" value="0"/>	656		
sec 5	<input type="text" value="Bend"/>	<input type="text" value="Vert. Up"/>	<input type="text" value="3"/>	<input type="text" value="45"/>	866	301	900
sec 6	<input type="text" value="Straight"/>		Dist (ft): <input type="text" value="50"/>	Angle (deg.): Up(+) Down(-) <input type="text" value="0"/>	897		
sec 7	<input type="text" value="Bend"/>	<input type="text" value="Horizontal"/>	<input type="text" value="3"/>	<input type="text" value="44"/>	1173	408	900
sec 8	<input type="text" value="Straight"/>		Dist (ft): <input type="text" value="15"/>	Angle (deg.): Up(+) Down(-) <input type="text" value="0"/>	1182		
sec 9	<input type="text" value="Bend"/>	<input type="text" value="Horizontal"/>	<input type="text" value="3"/>	<input type="text" value="80"/>	1928	671	900
sec 10	<input type="text" value="Straight"/>		Dist (ft): <input type="text" value="190"/>	Angle (deg.): Up(+) Down(-) <input type="text" value="0"/>	2044		

## Reverse pull (percent of max tension: 59.4%)

	Section Type:	Bend Type:	Dist (ft):	Radius (ft):	Angle:	Tension (lbs):	Sidewall Pressure (lbs):	Allowable Sidewall Pressure (lbs):
sec 1	Straight		190		0	166		
sec 2	Bend	Horizontal		3	80	271	94	900
sec 3	Straight		15		0	280		
sec 4	Bend	Horizontal		3	44	366	127	900
sec 5	Straight		50		0	397		
sec 6	Bend	Vert. Up		3	45	526	183	900
sec 7	Straight		800		0	1014		
sec 8	Bend	Vert. Down		3	45	1335	465	900
sec 9	Straight		50		0	1365		
sec 10	Bend	Vert. Up		3	90	2376	827	900