

OVERHEAD DISTRIBUTION GROUNDING SPECIFICATION

1.0 INSTALLATION

- 1.1 Where practicable, ground rods shall be driven to their full length in undisturbed earth. Ground rods shall be installed at least two feet from the face of the pole, with the tops of the rods at least 12 inches below ground.
- 1.2 At locations where ground rods cannot be driven the full length of the rod, rods may be bent (only if copper-coated) or cut in two and attached to the ground wire either in series or in parallel.
- 1.3 Ground rods placed in the pole hole must be in good contact with the pole backfill. Pole backfill in this instance shall contain sufficient fine material to prevent voids from forming near or around the ground rod.
- 1.4 The pole ground wire shall be #4 solid. Pole ground wire shall be attached to the rod with a ground rod clamp and shall be secured to the pole with staples. Staples shall be spaced two feet apart, except for the first eight feet above the ground and the top eight feet of the ground wire where spacing of staples shall be every six inches.

2.0 BONDING

- 2.1 Bonding between the ground rod and the system neutral shall be made by one continuous piece of ground wire in the most direct path.
- 2.2 Connections to the system neutral, and splices (if required), shall use compression-type connectors.
- 2.3 All equipment shall have at two connections from the frame, case, or tank to the system neutral or pole ground wire.

3.0 CONSTRUCTION SPECIFICATIONS FOR GROUNDING

- 3.1 All neutral conductors on the pole shall be bonded directly to each other, and connected to the pole ground wire if present. All equipment ground wires, neutral conductors, down guys, messenger wires, and surge-protection ground wires shall be interconnected and attached to a common (pole) ground wire in accordance with the requirements of the National Electrical Safety Code (NESC).
- 3.2 RUS borrowers shall install effectively grounded driven ground rods (assembly H1.1) or trench type grounding assemblies (assembly H2.1) a maximum of 1,320 feet (433 meters) apart along overhead distribution lines. Customer-owned or other installed electric service grounds shall not be counted in the above minimum grounding assembly requirement.

5.0 GUY INSTALLATION SPECIFICATION

5.1 GENERAL

- 5.1.1 Guy wire shall consist of 18M, Aluminum-clad steel guy strand.
- 5.1.2 Guys shall be installed before conductors are strung.
- 5.1.3 A guy locator (or marker) shall be installed on all down guys.
- 5.1.4 RUS required bonding clamps are to be securely installed between the anchor rod and the guy wire attached to the anchor rod.
- 5.1.5 CONTRACTOR shall note any possible guy conflicts with the design prior to stringing wire and preferably prior to installing the anchors/guys. CONTRACTOR will be required to correct guys contacting neutral conductors at CONTRACTOR cost if not brought to the engineer's attention prior to stringing conductor.
- 5.1.6 Single deadend structure guys shall be installed, as nearly as practicable, in line with the pull of conductors. Double deadend structures on angles shall be installed with the anchor kicked in by two feet to prevent the pole from leaning if a bisect guy is not installed. Bisect guys at line angle structures shall be installed as nearly as practicable to the true bisector of the line angle.
- 5.1.7 If the separation on the pole between any guy attachment bolt or hardware and any phase conductor attachment bolt is less than 15 inches, then a guy strain insulator assembly shall be installed at the top of the guy. Alternatively, an insulated extension link shall be installed in the primary conductor tap, deadend, or suspension angle subassembly where it attaches to the pole.

5.2 GROUNDING

- 5.2.1 Down guy and overhead guy wires shall be effectively grounded in accordance with Rule 215C2 of the NESC and in accordance with the assembly drawings, unless specified otherwise.

5.3 INSULATION

- 5.3.1 Fiberglass guy strain insulators shall be used to electrically insulate each guy strand which extends above a current-carrying wire. Insulators shall be installed at the top of the guy wire.
- 5.3.2 Additional insulators may be necessary to minimize the potential of any portion of a guy assembly from becoming energized within eight feet of the ground in the event the guy becomes slack or breaks below the lowest guy insulator.
- 5.3.3 Guys installed on tangent, double deadend assemblies shall have a minimum clearance to the neutral conductor of six inches and shall have a guy strain insulator(s) installed at the top of the guy that extends from the pole attachment to at least 12 inches past the neutral conductor. Alternatively, two guys without guy strain insulators may be installed, one on each side of the neutral, such that clearance between each guy wire and the neutral conductor is a minimum of 12 inches. For either of the above designs, the guy wire shall be effectively

bonded to ground in accordance with the NESC.

Mason County PUD No. 1

Anchoring Specification

General Requirements

- Contractor shall be responsible for installing the proper type of anchor at each anchor location.
- All anchors shall be pull tested to 20,000 pounds for one minute, unless otherwise directed by the Owner's representative.
- Anchors shall be installed so approximately six inches of the rod remains above ground.
- In cultivated fields, the projection of the anchor rod above ground may be increased to a maximum of 12 inches to prevent burial of the rod eye.
- All anchor holes must be backfilled and thoroughly tamped over the full depth of the hole.

Installation Specifications Per Anchor Type

Expanding Rock Anchors

- A hole—one-quarter inch in diameter larger than the unexpanded anchor—shall be bored into competent rock with a hand or power drill.
- Place the anchor into the bored hole.
- Put a bar through the large eye of the anchor rod.
- Turn the rod until the anchor is firmly expanded against the sides of the hole.
- Grouting shall be added to the hole if the rock exhibits weathering characteristics.

Screw Anchor

- The anchor shall be installed with a torque indicator. Shear bolts shall not be used.
- The anchor shall be installed so the departure angle between the anchor rod and guy strand is less than five degrees.
- Minimum required installed torque is per construction unit drawing.

Cross-Plate Anchors

- Cross plate anchors shall only be installed where it is not practical to install power-installed screw anchors or where power-installed screw anchors cannot be driven. Attempt should first be made to install power-installed plate anchors.
- Anchor plate shall be installed perpendicular to the guy strand.
- The anchor rod shall be installed in a rod trench or bore hole so the rod is aligned with the guy strand.

Mason County PUD No. 1

Pull Testing

Required Equipment

- Dynamometer rated no less than 30,000 pounds with an appropriate rigging attachment able to connect to the anchor rod and hydraulic equipment.
- Hydraulic equipment capable of pulling greater than 30,000 pounds in various positions.

Testing

- All anchors shall be tested to maximum required holding capacity as indicated on the construction unit drawings.
- Anchor shall be loaded evenly and in a direct line with the axis of the anchor rod.
- If creep exceeds four inches, the anchor has failed and test shall be terminated.
- If anchor creep does not exceed four inches under maximum tension, the installation shall be accepted.
- Failed anchors shall be replaced.

7.0 POLE SETTING SPECIFICATION

7.1 GENERAL REQUIREMENTS

- 7.1.1 Unless specifically detailed on construction drawings to be otherwise, pole setting depth shall be 10 percent of the pole length plus two feet for classes of poles less than “H” class. “H” class poles shall be 10 percent of the pole length plus two feet plus ½ foot for each increase in “H” class. For example, a 70-H4 shall be buried 10 percent of the pole length plus two feet plus 4/2 feet for a total burial depth of 11 feet.
- 7.1.2 Rake all angle and dead-end poles away from the conductor pull such that after sagging the conductor the pole top will be nine inches raked on angle poles and 12 inches raked on deadend poles. Raking refers to setting poles with a lean rather than leaning poles by tensioning guys after the pole is set and backfilled.
- 7.1.3 Pole stakes marking pole locations shall be preserved to the extent practicable by CONTRACTOR. Prior to removing pole stakes and drilling pole holes, CONTRACTOR shall establish reference offset marks to maintain proper pole alignment.
- 7.1.4 The CONTRACTOR shall ensure tangent poles are set plumb and in-line with poles behind and ahead.
- 7.1.5 Compaction of backfill material shall be adequate to prevent future settling of the ground surface at the base of the pole.
- 7.1.6 All field-drilled holes shall be treated with OSMOSE CU-89-RTU preservative in accordance with the MANUFACTURER’s recommendations, prior to installing bolts or other attachment hardware. Use of other preservatives must be approved by OWNER.

7.2 HANDLING & DELIVERY

- 7.2.1 Poles shall not be dragged on the ground. Cant hooks, pole tongs, or other pointed tools shall not be applied to the ground line section of any pole.
- 7.2.2 Poles containing indentations one-quarter inch or more deep over 20 percent or more of the pole circumference or more than one-half inch deep at any point that can be attributed to loading or handling slings shall be rejected.
- 7.2.3 Other indentations or abrasions (e.g., forklift damage, chain-saw damage) shall not be more than one tenth of the diameter of the pole at the point of damage; in no case shall indentations or abrasions exceed one inch in depth. Such damage is only permitted in an oversized section, where the excess of wood shall be taken into consideration in evaluating the effects of the damage. In any case, the remaining circumference shall meet or exceed the minimum requirements.
- 7.2.4 Backfill with 1-1/4” minus gravel.

7.3 POLE GAINS

- 7.3.1 Poles shall be set so that the crossarm gains face in opposite directions on every other pole, except where noted below.
- 7.3.2 On sloping terrain, the crossarms shall be installed on the uphill side of the pole.
- 7.3.3 At stringing deadends, the last two poles shall be set so that the pole gains face the deadend.
- 7.3.4 On long spans, the poles shall be set so that the crossarm is located on the side of the pole away from the long span.
- 7.3.5 Pole top insulator brackets and pole top pins shall be installed on the side of the pole opposite the gain.
- 7.3.6 A pole gain shall be installed for all crossarms that are installed on poles without a gain already cut into the pole by the pole supplier prior to treatment.

7.4 CROSSARMS

- 7.4.1 DEADEND BUCKARM STRUCTURE LOCATIONS
 - A. Standard crossarm framing shall be upper arms for back span (source) conductors and lower arms for ahead (load) conductors.
 - B. Crossarms shall be mounted on the side of the pole opposite the conductors being supported.
 - C. Crossarms shall be mounted perpendicular to the pole and to the alignment of the conductors.
- 7.4.2 LINE ANGLE BISECT STRUCTURES
 - A. Crossarms shall be mounted on the pole such that the crossarms bisect the primary line angle.
 - B. Crossarms shall be mounted perpendicular to the pole.
- 7.4.3 Crossarms that are damaged during pole framing, pole setting, or conductor stringing, tensioning, clipping, and tying shall be replaced by CONTRACTOR.

7.5 REMOVED POLES

- 7.5.1 Removed poles and wood crossarms may be made available to local landowners on a first-come-first-serve basis. CONTRACTOR shall be responsible for coordination with landowners, loading, transporting, and unloading poles and crossarms, obtaining signatures from recipient landowners on the "Disposition of Wood Products" release form furnished by OWNER, and providing a copy of the "Consumer Information Report" on Pentachlorophenol Pressure Treated Wood to recipient landowners. Poles or crossarms not given to local landowners shall become the property of the CONTRACTOR.

Mason County PUD No. 1

Conduit Installation Specifications

GENERAL

- This specification describes the requirements for the installation of conduit for use with electric underground cables.

SITE CONDITIONS

- The ground area along the route for the conduit installation shall be clear of obstructions that may impact safety.
- Sufficient area shall be allowed for excavated material to be set back from the excavation or material shall be removed from the immediate area.
- Sufficient area shall be provided for safe and unimpeded access by workers installing the conduit.

EXCAVATION SIZE AND CLEARANCE

- The excavation shall allow for the overall dimensions of the specified conduit spacing or duct bank. When determining the dimensions, space for workers and bedding material shall be included.
- The excavation shall comply with safety standards for slope and worker access as necessary. Shoring shall be provided when required to meet safety codes or regulations.

BORING

- Drilling methods shall generally consist of drilling a pilot hole the length of the bore, followed by reaming and pullback of the pipeline. Ream borehole multiple times, as necessary. The equipment and methods used to complete the bore and install piping shall be determined by the Contractor.
- The drill staging area shall be kept neat and orderly and disturb as little area as possible. The pipe staging area shall disturb as little area as needed to accommodate workers and equipment, and to string, fuse, and inspect the pipe.
- Install all pulleys, rollers, bumpers, alignment control devices and other equipment required to support and protect the new pipe from damage during installation.
- Utilize a drilling fluid cleaning/recycling system. Entry and exit pits shall be sized and constructed to completely contain drilling fluid.

Mason County PUD No. 1

- Borehole survey instrumentation shall be used to monitor line and grade of the pilot hole. Contractor shall maintain records documenting the line and grade of the pilot hole.
- The depth of the conduit shall be identified by a stake with the depth every 10 feet along the route in unpaved areas and by the depth written in marker paint every 10 feet along the route in paved areas.
- Pilot hole shall be back-reamed to accommodate pipe. Contractor shall select the reamer size and number of passes required.
- Monitor tension forces on pipe during pullback. Do not exceed maximum stresses recommended by the pipe supplier.

TRENCHING

- Construction shall be arranged so that trenches may be left open for the shortest practical time to avoid creating a hazard to the public and to minimize the likelihood of collapse of the trench due to other construction activity, rain, accumulation of water in the trench, etc.
- All trench depths are at a minimum as measured from final grade to the top of the conduit. The routing shall be as shown on the staking sheets and drawings, unless approved by the OWNER. If rock or other difficult digging is involved, the CONTRACTOR shall determine the nature and difficulty, and the OWNER shall determine whether re-routing, rock trenching, plowing, or other changes are necessary. Loose soil or crumbly rock shall not be considered as difficult digging. The trench widths, if specified, are at a minimum and should be increased as necessary to obtain the required depth in loose soils.
- Where multiple facilities are to be installed in one trench, extra width and depth shall be provided to accommodate proper separation and allow for soil falling into the trench during the installation of the first facility.
- Care shall be exercised to minimize the likelihood of water flow since this may cause trench damage and reduction in trench depth. If water flow occurs, the trench shall be cleared to the specified depth before installing any facilities.
- All trenches shall follow straight lines between staked points to the greatest extent possible. The trenches shall be dug so that the bottom has a smooth grade. Large rocks, stones, and gravel in excess of one inch shall be removed from the bottom of the trench. Where this cannot be accomplished, bedding material shall be placed in the bottom of the trench.
- Conduit shall be installed a minimum of 42" below grade with 48" as the preferred depth, unless otherwise noted.

Mason County PUD No. 1

BEDDING MATERIAL AND PREPARATION

- Bedding material shall be sand, crushed rock less than 1.5 inches, pea gravel or, when approved by the OWNER's representative, native soil.
- Bedding material shall be installed to cover the entire bottom of the excavation to a depth of two inches and be graded level.
- Bedding material shall be graded level and compacted.

CONDUIT INSTALLATION

- Care shall be taken to ensure the conduit is not damaged during installation.
- Conduit shall be protected from site materials or water entering ends of the conduit.
- Joints shall be made in accordance with the manufacturer's specifications. Glue and adhesives shall be uniformly distributed along the surface of the conduit joint. Care shall be taken to prevent excessive glue or adhesives from being left on the interior surface of the conduit.
- Conduit shall be inserted the full length of couplers. Threaded joints shall be fully threaded onto the conduit ends.
- Spacing between conduits within the trench shall be maintained in a uniform manner.
- When parallel with or crossing other utility lines or culverts, spacing shall be maintained as specified on the drawings.

BACKFILLING

- Before any backfilling operations commence, the CONTRACTOR and the OWNER's representative shall jointly inspect all trenches, cable placement, risers, pedestals, and other construction that will not be accessible after backfilling, and an inventory of units shall be taken. If corrections are required, a second inspection shall be made after completion of the changes.
- Trenches shall be backfilled only after the conduit is completely assembled.
- Backfill material up to a level of six inches above the top of the largest conduit shall be free of rocks and debris larger than one inch.
- Backfill material shall be sand, pea gravel, crushed rock, or native soil when approved by the OWNER's representative.
- Backfill material shall not be saturated with water.
- Trenches shall be backfilled and compacted such that in the top 2 feet, horizontal layers shall not exceed 4 inches in depth before compaction. No layer below the top 2 feet shall exceed 8 inches in depth before compaction. See WSDOT Std Spec 2-03.3(14)C, Method C compaction.

Mason County PUD No. 1

WARNING TAPE

- Red warning tape, three inches wide with a locating strip, shall be installed six inches above all conduit, cable, or duct, if placed by trenching, or plowing.

PULL TAPE

- Upon completion of the conduit installation, a pull tape shall be installed by use of compressed air and a mandrel. The integrity of the conduit must be demonstrated.
- The pull tape ends shall be secured in a vault or at a pole riser so as to be available for conductor installation at a later time.
- Rated strength of the pull tape (mule tape) shall be 2,500 pounds minimum.

FINISHING

- All exposed ends of conduit shall be plugged to prevent the entrance of foreign matter and moisture into the conduit. Burrs or sharp projections which might damage cable shall be removed. End bells shall be installed on the ends of all conduits.
- All installed conduits shall be "proofed" using the appropriate mandrel, and have a 2500 pound, 3/4" sequentially numbered, continuous "mule tape" installed for future cable pulling. Certification of the test mandreling shall be provided to OWNER acceptance

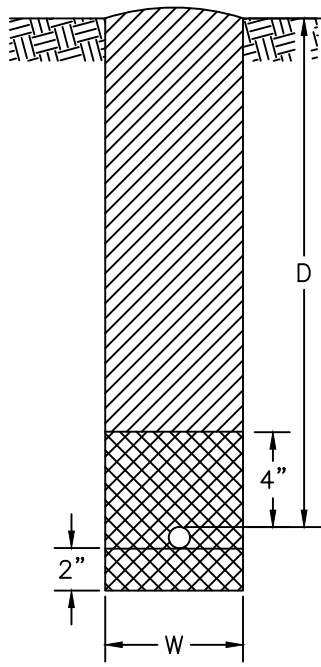

UR2 (D x W)
TRENCHING UNIT
ONE CONDUIT

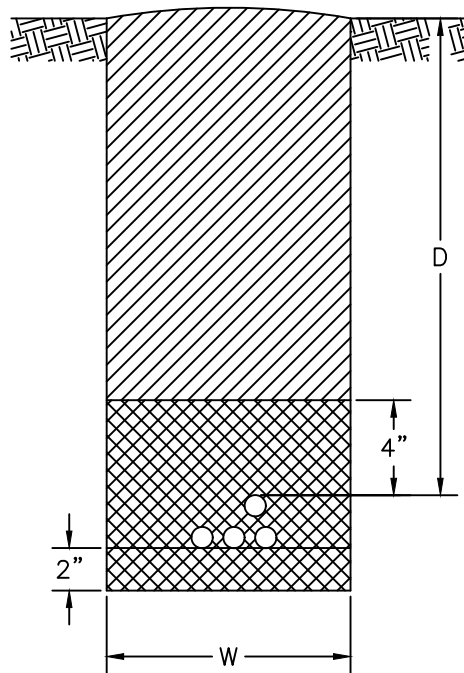

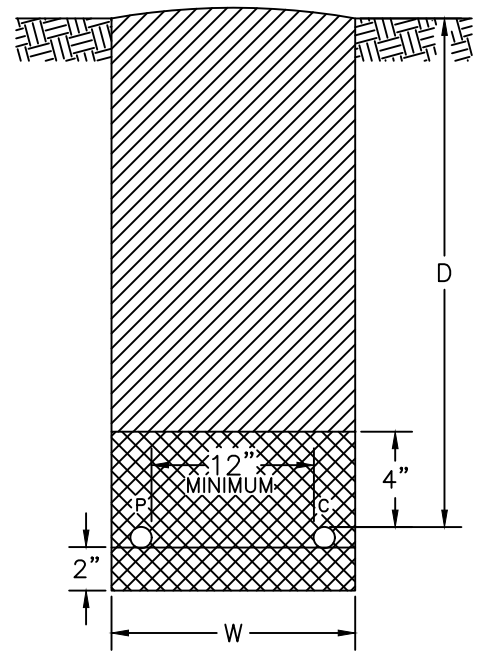

UR2-1 (D x W)
TRENCHING UNIT
MULTIPLE POWER CONDUITS
PRIMARY, SECONDARY OR SERVICE



UR2-2 (D x W)
TRENCHING UNIT
POWER AND COMMUNICATION CONDUIT
OR OTHER UTILITY

Joint trench at least 2' W

LEGEND

-  SAND OR CLEAN SOIL
-  COMPACTED BACKFILL UNLESS OTHERWISE SPECIFIED
-  UNDISTURBED EARTH

NOTES:

- 1) DEPTH (D) IS TO BE A MINIMUM OF 36" TO TOP OF POWER CONDUIT FOR PRIMARY (HIGH VOLTAGE) AND 24" FOR SECONDARY AND WIDTH (W) IS A MINIMUM OF 12".
- 2) DEPTHS SPECIFIED ARE TO FINISHED GRADE.
- 3) SAND BEDDING IS NOT PART OF THESE UNITS AND WILL BE SPECIFIED AS NEEDED.
- 4) BACKFILLING IS PART OF ALL TRENCHING UNITS INCLUDING JOINT-USE TRENCHES.
- 5) AREA DISTURBED BY TRENCHING SHALL BE LANDSCAPED TO PRE-EXISTING CONDITION.
- 6) OTHER UTILITIES MAY REQUIRE DIFFERENT TRENCH DEPTHS AND SPACING. COORDINATE WITH THE OTHER UTILITIES FOR THEIR REQUIREMENTS.
- 9) PUD TO INSPECT TRENCH AND CONDUIT PRIOR TO BACKFILL.

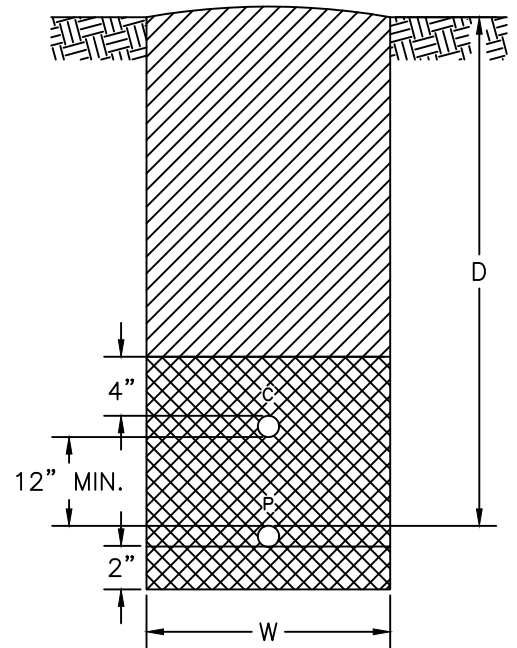

UR2-2 (D x W)
TRENCHING UNIT
POWER AND COMMUNICATION CONDUIT
(OPTIONAL CONDUIT LAYOUT)



TRENCH DETAIL(S)

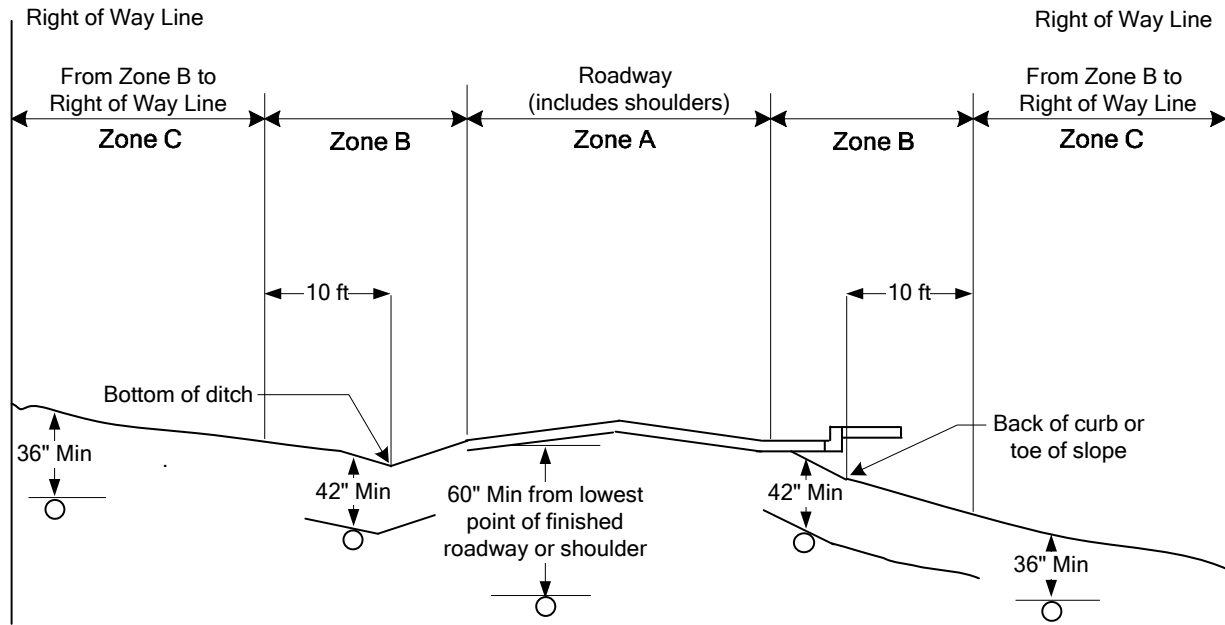

Longitudinal Coverage Detail

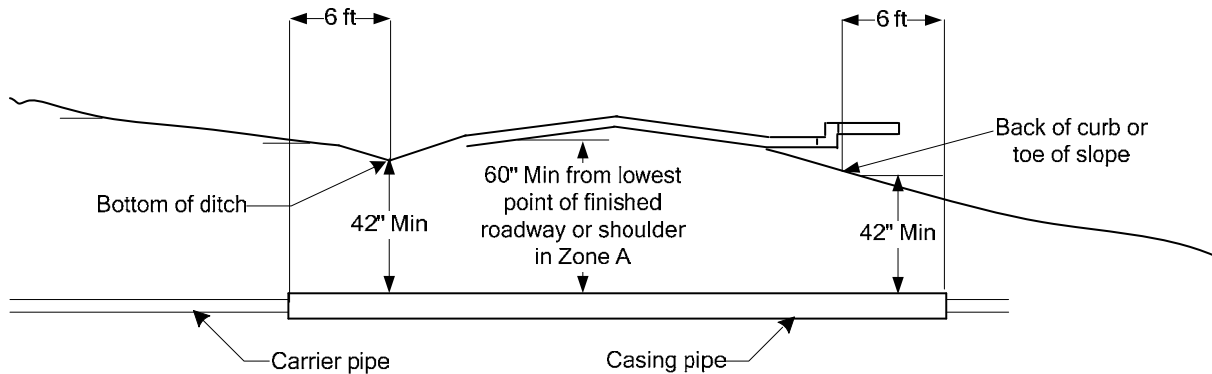

Note:
Casing pipes shall extend a minimum of 6 feet beyond the toe of fill slopes, or bottom of ditch line, or outside curb.

Crossing Coverage Detail

Minimum Cover for Pipe Installation

Figure 120-3

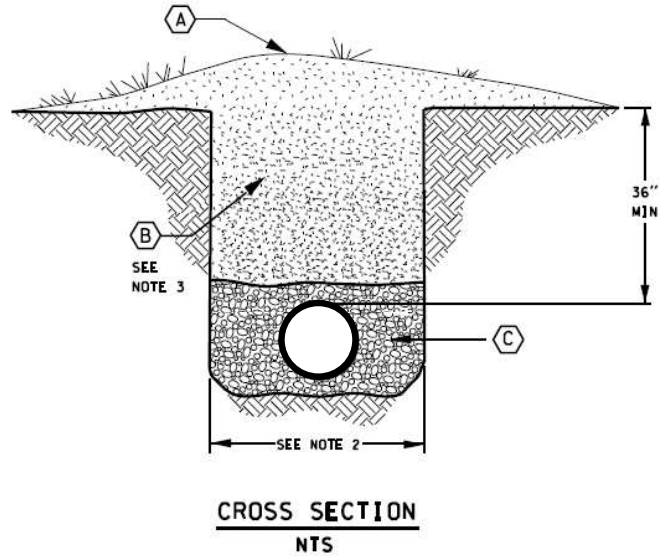
**LEGEND**

- (A) Surface treatment to restore existing to match adjacent (seeding, bark, etc.).
- (B) Native material or as directed by WSDOT.
- (C) Bedding material. Bedding material depth over and beneath pipe casing shall be half the diameter of pipe casing or 6 inches, whichever is less.

GENERAL NOTES

1. Trenching and pipe installation shall meet the requirements of WSDOT Standard Specification 7-08.
2. Maximum trench width shall be outside casing pipe width plus 1 foot either side of casing pipe.
3. Compaction shall be method _____ per Standard Specification Section 2-03.3 (14) C.
4. When connecting to an existing facility under the pavement, pavement restoration may, at the department's discretion, include the full lane width and encroached shoulder.
5. Casing pipes shall extend a minimum of six (6) feet beyond the toe of fill slopes, bottom of ditchline, or outside of curb.

Open Trench Detail
Figure 120-4b

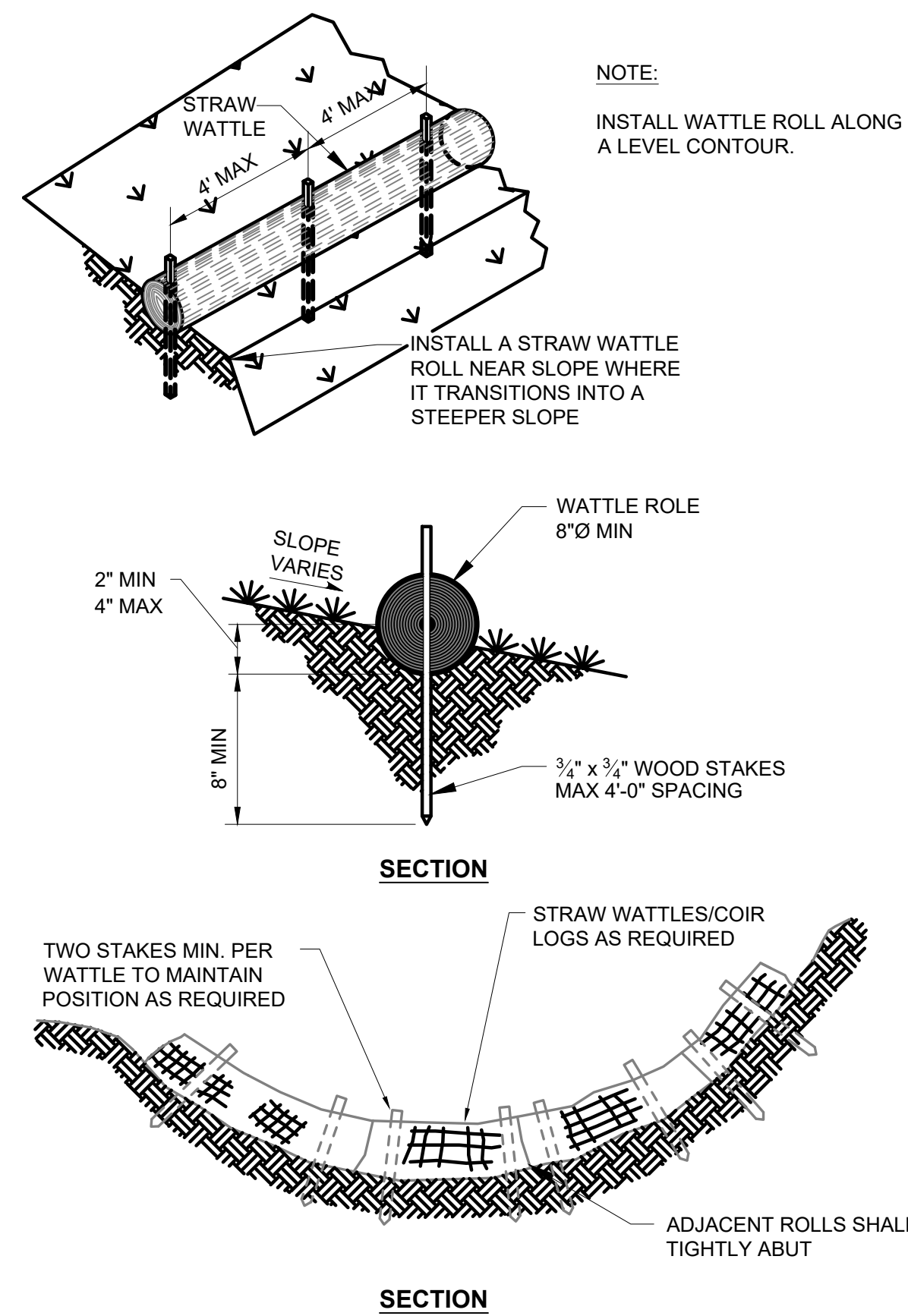

1
TYP
STRAW WATTLE ROLL DETAIL
NOT TO SCALE

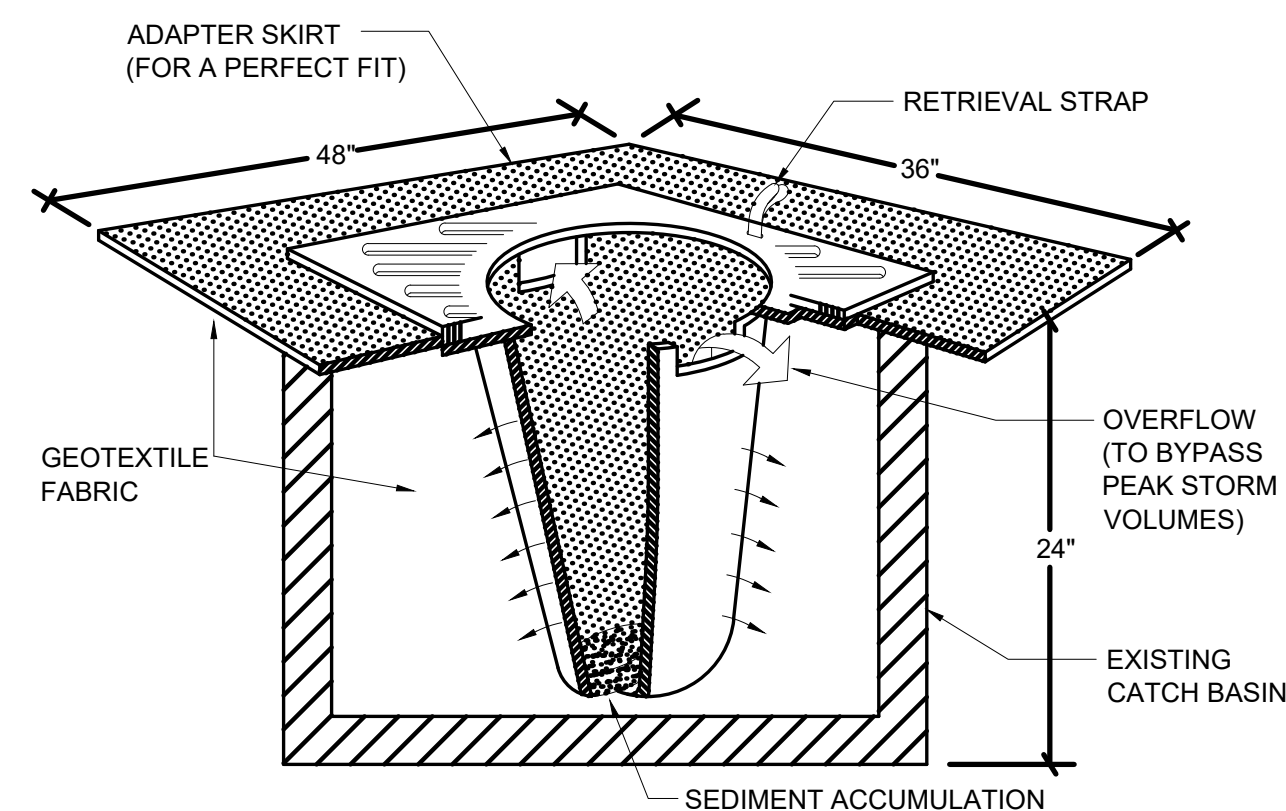

2
TYP
INLET PROTECTION DETAIL
NOT TO SCALE

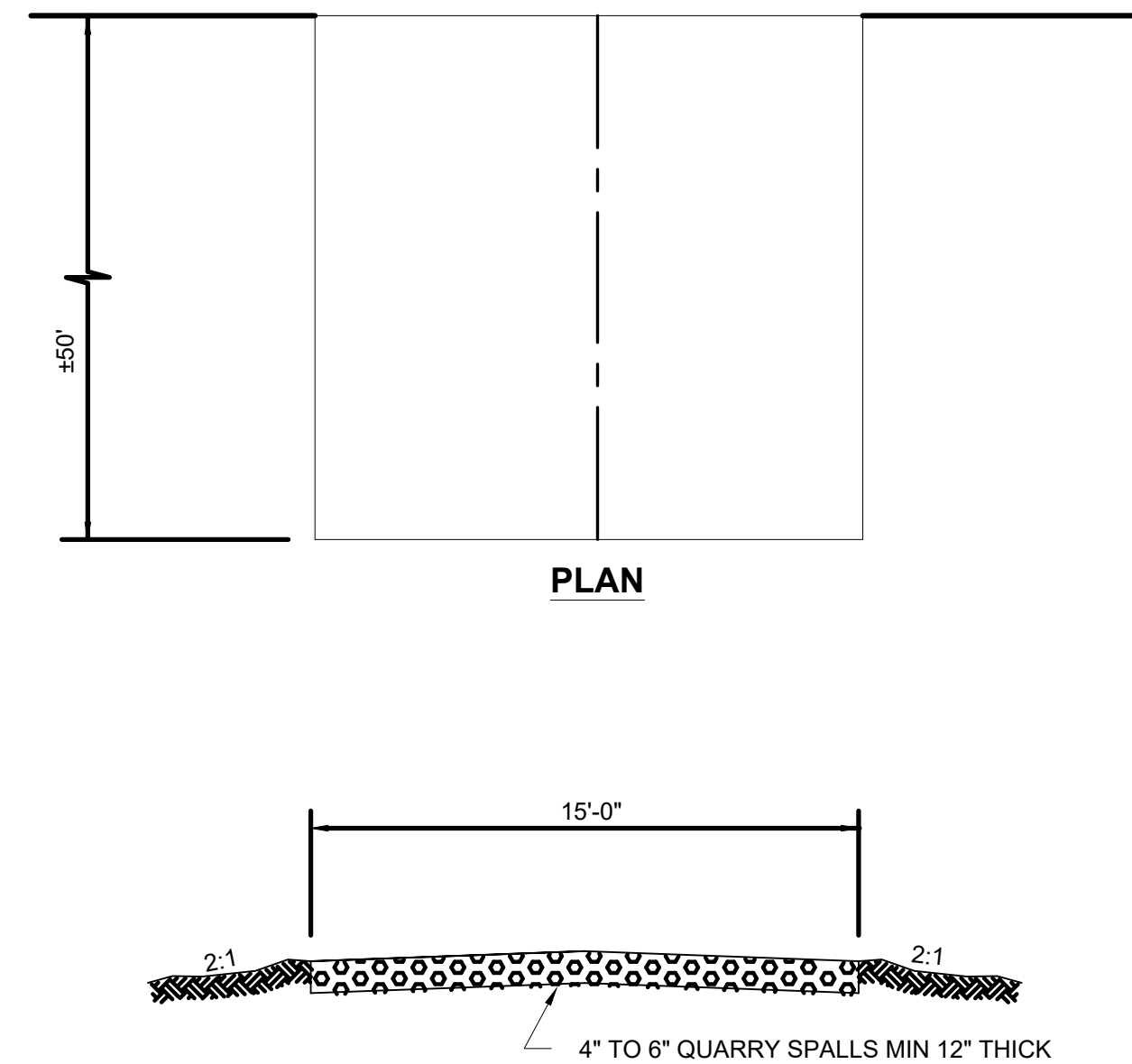

3
TYP
CONSTRUCTION ENTRANCE DETAIL
NOT TO SCALE

EROSION/SEDIMENTATION CONTROL NOTES:

THE CONTRACTOR SHALL PROVIDE EROSION CONTROL METHODS ACCORDING TO THE WASHINGTON STATE DEPARTMENT OF ECOLOGY'S (WSDOE) "STORMWATER MANAGEMENT MANUAL FOR WESTERN WASHINGTON", VERSION 2012 AND 2014 AMENDMENTS. THE FOLLOWING ARE A FEW OF THE MINIMUM REQUIREMENTS AND SHOULD NOT BE INTERPRETED TO EXCLUDE ANY EROSION CONTROL PRACTICES AS SPECIFIED IN THE WSDOE STORMWATER MANUAL.

1. ALL LIMITS OF CLEARING AND AREAS OF VEGETATION PRESERVATION SHALL BE OBSERVED DURING CONSTRUCTION.
2. ALL REQUIRED SEDIMENTATION/EROSION CONTROL FACILITIES MUST BE IN OPERATION PRIOR TO LAND CLEARING AND/OR OTHER CONSTRUCTION TO INSURE THAT SEDIMENT LADEN WATER DOES NOT ENTER THE DRAINAGE SYSTEM. ALL EROSION AND SEDIMENT FACILITIES SHALL BE MAINTAINED IN A SATISFACTORY CONDITION UNTIL SUCH TIME THAT CLEARING AND /OR CONSTRUCTION IS COMPLETED AND THE POTENTIAL FOR ON-SITE EROSION HAS PASSED. THE IMPLEMENTATION, MAINTENANCE, REPLACEMENT AND ADDITIONS TO EROSION/SEDIMENTATION CONTROL SYSTEMS SHALL BE THE RESPONSIBILITY OF THE CONTRACTOR.
3. THE EROSION AND SEDIMENTATION CONTROL SYSTEMS DEPICTED ON THE DRAWINGS ARE IDENTIFIED IN SENSITIVE AREAS. NOT ALL EROSION CONTROL MEASURE ARE DEPICTED ON THE DRAWINGS. THE CONTRACTOR SHALL FOLLOW THE REQUIREMENTS OF THE BMPs THROUGHOUT THE ENTIRE PROJECT. AS CONSTRUCTION PROGRESSES AND AS UNEXPECTED OR SEASONAL CONDITIONS DICTATE. THE CONTRACTOR SHOULD ANTICIPATE THAT MORE EROSION AND SEDIMENTATION CONTROL FACILITIES WILL BE NECESSARY TO INSURE COMPLETE SILTATION CONTROL ON THE PROPOSED SITE. DURING THE COURSE OF CONSTRUCTION IT SHALL BE THE OBLIGATION AND RESPONSIBILITY OF THE CONTRACTOR TO ADDRESS ANY NEW CONDITIONS THAT MAY BE CREATED BY HIS ACTIVITIES AND TO PROVIDE ADDITIONAL FACILITIES, OVER AND ABOVE THE MINIMUM REQUIREMENTS, AS MAY BE NEEDED TO PROTECT ADJACENT PROPERTIES AND THE WATER QUALITY OF THE RECEIVING DRAINAGE SYSTEM.
4. AT NO TIME SHALL MORE THAN ONE FOOT OF SEDIMENT BE ALLOWED TO ACCUMULATE WITHIN A CATCH BASIN INLET PROTECTION. THE CONTRACTOR SHALL BE RESPONSIBLE FOR REMOVING AND PROPERLY DISPOSING OF THE SEDIMENT. ALL CATCH BASINS, CONVEYANCE LINES AND DITCHES ALONG CIVIC DRIVE SHALL BE CLEANED PRIOR TO PAVING.
5. THE CONTRACTOR SHALL REMOVE MATERIAL DROPPED, WASHED OR TRACKED FROM VEHICLES ONTO THE CITY RIGHT-OF-WAY OR INTO THE EXISTING STORM DRAINAGE SYSTEM. DEBRIS SHALL NOT BE WASHED INTO THE STORM DRAINAGE SYSTEM ON CIVIC DRIVE.
6. TEMPORARY EROSION CONTROL FACILITIES SHALL BE INSPECTED WEEKLY AND MAINTAINED WITHIN 24 HOURS FOLLOWING A STORM EVENT. SEDIMENT SHALL BE REMOVED TO INSURE THE FACILITIES WILL FUNCTION PROPERLY. THE FACILITIES SHALL BE SATISFACTORILY MAINTAINED UNTIL CONSTRUCTION IS COMPLETED AND THE POTENTIAL FOR ON-SITE EROSION HAS PASSED.
7. ALL STORM DRAIN INLETS MADE OPERABLE DURING CONSTRUCTION SHALL BE PROTECTED SO THAT STORMWATER RUNOFF SHALL NOT ENTER THE CONVEYANCE SYSTEM WITHOUT FIRST BEING FILTERED OR OTHERWISE TREATED TO REMOVE SEDIMENT.
8. NO DISTURBED SOIL SHALL REMAIN UNSTABILIZED FOR MORE THAN TWO DAYS.
9. SEDIMENT TRAP/POND BAFFLES SHALL BE EMBEDDED IN SIDE SLOPES.

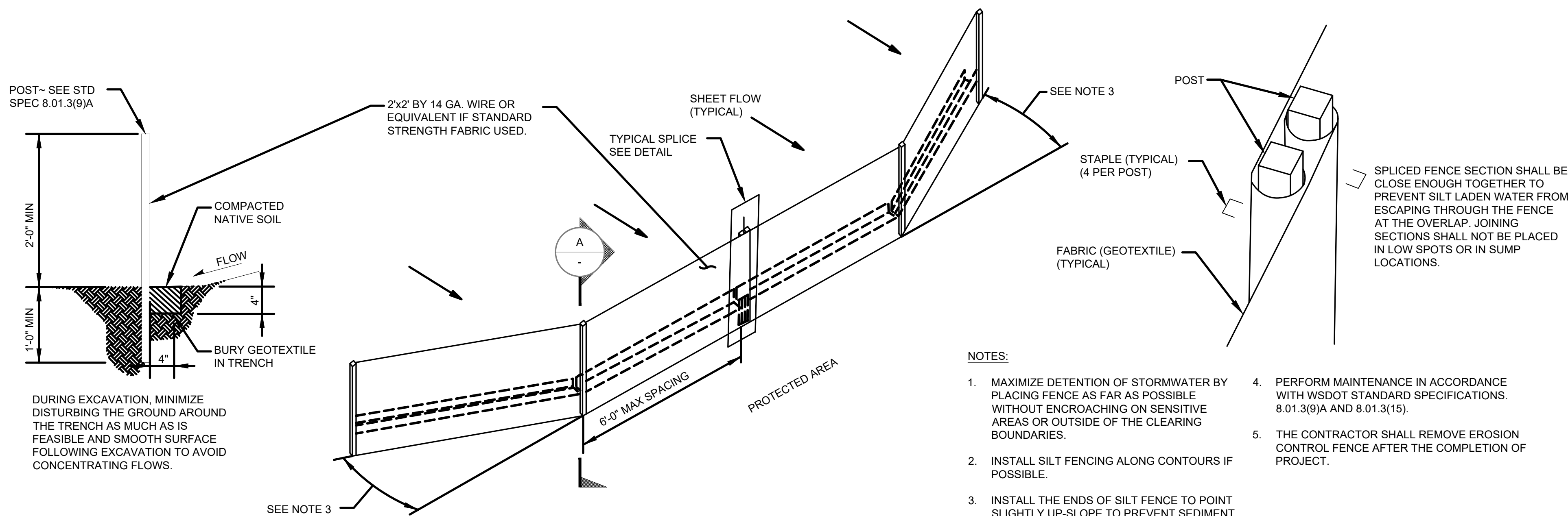

- NOTES:**
1. MAXIMIZE DETENTION OF STORMWATER BY PLACING FENCE AS FAR AS POSSIBLE WITHOUT ENCROACHING ON SENSITIVE AREAS OR OUTSIDE OF THE CLEARING BOUNDARIES.
 2. INSTALL SILT FENCING ALONG CONTOURS IF POSSIBLE.
 3. INSTALL THE ENDS OF SILT FENCE TO POINT SLIGHTLY UP-SLOPE TO PREVENT SEDIMENT FROM FLOWING AROUND THE ENDS OF THE FENCE.
 4. PERFORM MAINTENANCE IN ACCORDANCE WITH WSDOT STANDARD SPECIFICATIONS. 8.01.3(9)A AND 8.01.3(15).
 5. THE CONTRACTOR SHALL REMOVE EROSION CONTROL FENCE AFTER THE COMPLETION OF PROJECT.

4
TYP
SILT FENCE DETAILS
NOT TO SCALE

MASON COUNTY PUD 1
EROSION CONTROL DETAILS

8.0 UNDERGROUND CABLE INSTALLATION

8.1 GENERAL

- 8.1.1 This specification describes the requirements for the installation of underground distribution medium voltage cable as specified.
- 8.1.2 All construction work shall be accomplished in a thorough and workmanlike manner in accordance to the plans, specifications, and the construction drawings.
- 8.1.3 All material and equipment used in the construction shall be stored so as to be protected from deteriorating effects of the elements.

8.2 HANDLING OF CABLE

- 8.2.1 The cable shall be handled carefully at all times to avoid damage, and shall not be dragged across the ground, fences, or sharp objects. Care shall be exercised to avoid excessive bending of the cable. The ends of the cable shall be sealed at all times against moisture with suitable end caps. Where it is necessary to cut the cable, the ends shall be terminated or sealed immediately after the cutting operation.
- 8.2.2 The CONTRACTOR shall ensure that the minimum bending radius of primary cable is a minimum of 12 times the overall diameter of the cable. The minimum bending radius of secondary and service cable is six times the overall diameter of the cable. In all cases, the minimum radius specified is measured to the surface of the cable on the inside of the bend. Cable bends shall not be made within six inches of the cable terminal base.
- 8.2.3 Splices are not allowed unless specifically approved by the OWNER's representative in writing.

8.3 CABLE INSTALLATION IN CONDUIT AND DUCT

- 8.3.1 All pulling operations shall use at least 2,500-lb mule-tape; rope is not allowed.
- 8.3.2 All burrs and obstructions shall be cleared from duct or conduit by pulling a mandrel approximating the inside diameter of the conduit prior to pulling any cable.
- 8.3.3 To avoid abrasion and damage of the cable jacket when guiding the cable from the reel to the duct mouth, all guides should be in the form of large diameter, smooth-surfaced, free turning sheaves or rollers. If guide tubes or chutes must be used, they should have smooth, burr-free working surfaces, well flared entrances, largest possible bend radii, and shall be securely anchored so that cable passes smoothly over them. Cable tension going into the guides shall be kept as low as possible, by mounting the cable reel in sturdy jacks, carefully leveling the reel shaft, and lubricating the reel arbor holes and shaft with grease. Braking of the reel should be done only to prevent reel over-run when the pull is slowed or stopped, or on steep downhill runs where cable weight is enough to overcome cable-duct friction.

- 8.3.4 Water based cable lubricants shall be used when pulling in any cable into duct or conduit. Grease, oil, or wax-based lubricants are expressly prohibited. The lubricant shall be American Polywater type J or similar. Use liberally, but not less than that recommended by the lubricant manufacturer.
- 8.3.5 Woven wire pulling grips or “baskets” may be used to pull in easy pulls. The ends of the cable shall be sealed prior to pulling. Since the compressive force applied by the pulling grip may damage or disturb the underlying cable, CONTRACTOR shall cut off the cable in the grip and approximately three feet behind the grip.
- 8.3.6 If pulling tensions exceed 1,500 pounds, the CONTRACTOR shall stop and consult with the OWNER’s representative as to the best course of action to limit the pulling tension.

8.4 INSTALLATION OF CABLE AND DUCT IN TRENCH

- 8.4.1 All cable and duct must be placed in the trench as soon after trenching as feasible. The duct placement shall be done by hand, under the constant supervision by the OWNER’s representative, assuring no damage to the cable occurs.
- 8.4.2 Cable and duct shall be carefully inspected as it is removed from the reel to be certain it is free from visible defects. The OWNER will decide upon corrective action when defects are discovered.
- 8.4.3 Where more than one duct is to be placed in a trench, the spacing required on the drawings or by the OWNER shall be observed. Care shall be taken that any soil falling into the trench during the laying of the first duct does not reduce the clearances of the last duct below that specified. Should this occur, the excess soil shall be removed carefully by hand or with equipment that will not damage the installed cable.
- 8.4.4 Cable trench shall be mechanically compacted at least 36 inches from all riser poles, pads, pedestals, and terminal points.
- 8.4.5 If direct bury cable is specified, sufficient slack, and in no case less than 24 inches, shall be left at all risers, transformers, pads, pedestals, and terminal points so that movements of cable after backfilling will not cause damaging strain on the cable or terminals.
- 8.4.6 During placement of duct, the duct shall be pulled straight in the trench prior to backfilling with very minimal or no side-to-side waviness, to facilitate ease of pulling in cable.

8.5 PLOWING EQUIPMENT REQUIREMENTS

- 8.5.1 A prime mover with a minimum of 50,000 foot-lbs. drawbar pull and equipped with rubber pads for operating on oiled or paved roads and/or grousers for gravel roads is required. Rubber-tired grader or parsons-type plows are not allowed. Rubber-tired pull equipment will be allowed in addition to a track-type prime mover. Equipment for compaction after plow will be provided by the CONTRACTOR and will be available at the job site.
- 8.5.2 All plowing equipment will be equipped with a vibratory attachment as needed to ease drawbar pull, bed cables, and relieve cable tension as required by the OWNER.

- 8.5.3 The plow shall be capable of placing cable up to four feet beyond the edge of the road and three feet in a ditch line and still plow the cable in a minimum of six inches below the specified depth under all terrain conditions of plow utilization.
- 8.5.4 The plow shall be provided with separate reel carriers for placing four power cables or ducts and one communication duct and cable.
- 8.5.5 The feed shoe shall have rollers to conform to the cable or duct at a radius of not less than 15 times the diameter of the cable or duct.
- 8.5.6 The cable shall *not* pass over stationary guides, rollers or sheaves which will permit a bend radius of less than 15 times cable or duct diameter.
- 8.5.7 The width of the tooth and feed shoe shall not exceed the cable or duct diameter by more than two inches.
- 8.5.8 The plow shall be provided with a means to assure positive hold-down of the plow blade to provide proper depth at all times.

8.6 PLOWING PROCEDURES

- 8.6.1 An OWNER's representative will be on-site at all times during plowing operation to assure compliance with these specifications.
- 8.6.2 Starting and termination points of the plowing operation shall be excavated prior to the cable installation to reduce possible cable damage and to assure sufficient burial depth. The slot made in the soil by the plow shall be closed immediately by driving a vehicle track or wheel over the slot or by other suitable means.
- 8.6.3 Care shall be exercised to feed the cable or duct into the ground through the plow loosely and at minimum tension.
- 8.6.4 If, during the plowing operation, the plow should strike a buried object or rock that would stop the equipment and necessitate removal of the plow from the ground, the plow shall be removed from the ground carefully and without backing the plow. If backing the plow cannot be avoided, the cable shall be uncovered a sufficient distance behind the plow so that the cable and/or duct can be easily lifted from the trench with the plow.
- 8.6.5 Cable and/or duct shall be inspected carefully as it is paid out from the reel to be certain that it is free from visible defects. Every instance of damaged cable observed at any time, whether prior to installation, during installation, or when discovered by test or observation subsequent to installation, shall be immediately called to the attention of the OWNER. Repair, correction, or replacement of such damage shall be completed promptly and in accordance with the written instruction of the OWNER.

8.7 SPECIAL COORDINATION REQUIREMENTS DURING PLOWING

- 8.7.1 The CONTRACTOR shall review the staking sheets and the site with the OWNER prior to the start of construction. The CONTRACTOR, at that time, shall propose any desirable changes or clarifications. These changes, if approved by the OWNER, shall be made and recorded on the staking sheets.

- 8.7.2 In the event that rock is encountered during the plowing operation so that the buried cable cannot be installed to the required minimum depths in soil, the CONTRACTOR shall determine for the OWNER the nature and extent of the rock encountered. Based on this information, the OWNER will determine whether the cable or duct is to be rerouted or trenched in rock.
- 8.7.3 Due to the necessity of making on-the-spot corrections and changes on staking sheets, it may not be possible for the OWNER to issue revised staking sheets to the CONTRACTOR in all cases. When changes are made, dated, and initialed by the OWNER on a set of the CONTRACTOR's staking sheets, it shall be the CONTRACTOR's responsibility to transfer these changes to all other sets of staking sheets being used by the CONTRACTOR for construction purposes.

8.8 TAGGING OF CABLE

- 8.8.1 The cables shall be tagged as they are being laid. The identification shall be of a permanent type, such as plastic or corrosion resistant metal tags. The tag must be securely attached to the cable. Paper or cloth tags are not acceptable.

8.9 PRIMARY CABLE TERMINATIONS AND ELBOWS

- 8.9.1 All cable terminals shall be installed in accordance with the manufacturer's instructions. They must be suitable for the size and type of cable that they are used with and for the environment in which they will operate. Any indication of misfit, such as a loose or exceptionally tight fit, must be called to the OWNER's attention. The outer conductive surface of the termination must be bonded to the system neutral. A heat-shrink or cold-shrink must be installed to seal between the body of the termination and the cable jacket.
- 8.9.2 A portable cover or shelter shall be available for use when terminations are being prepared, to keep rain, snow, and windblown debris off the insulating surfaces of cable and terminations. Since cleanliness is essential in the preparation and installation of primary cable fittings, care shall be exercised to prevent the transfer of conducting particles from the hands to insulating surfaces. Mating surfaces shall be wiped with a solvent such as denatured alcohol to remove any possibly accumulation of dirt, moisture, or other conducting materials. A silicone grease or similar lubricant should be applied afterwards in accordance with the manufacturer's recommendations. Whenever prefabricated cable devices are opened, the de-energized mating surfaces shall be lubricated with silicone grease before the fittings are reconnected.

8.10 SECONDARY AND SERVICE CONNECTIONS

- 8.10.1 The ends of all secondary cables terminated below ground shall be long enough to reach at least 12 inches above the top of the underground enclosure.
- 8.10.2 A suitable inhibiting compound shall be used with all secondary and service connections.
- 8.10.3 All secondary cable connections located below grade or in secondary pedestals shall be made with pre-insulated secondary connector blocks. Diving bells with open terminals or any other connection that depends on tape is not acceptable.

- 8.10.4 All transformer secondary phase terminal connections shall be completely insulated. If the secondary phase terminals are threaded studs, the connection shall be made with a pre-insulated secondary transformer connection block. If the transformer has secondary spades, the spades shall be covered with insulating boots. Boots used for insulation shall be taped so that they cannot be readily slipped off.
- 8.10.5 Secondary connections to terminals of pole-mounted transformers shall be made so that moisture cannot get inside the cable insulation. This may be accomplished by covering the terminals and bare conductor ends with an appropriate moisture sealant or providing a drip loop.

8.11 INSPECTION AND INVENTORY OF BURIED UNITS

- 8.11.1 Before any backfilling operations commence, the CONTRACTOR and the OWNER's representative shall jointly inspect all trenches, cable placement, risers, pedestals, and other construction that will not be accessible after backfilling, and an inventory of units shall be taken. If corrections are required, a second inspection shall be made after completion of the changes.

8.12 EQUIPMENT PADS

- 8.12.1 The site shall be cleared of all debris and excavated to the specified depth. Gravel or sand may be added to the site and thoroughly compacted. The pad shall be installed level at finished grade.

8.13 EQUIPMENT ENCLOSURES

- 8.13.1 Excavations for "sleeves" and other below-grade enclosures shall be made so as to disturb the surrounding earth as little as practicable. When enclosures are of fiber, plastic, or other semi-flexible material, backfilling shall be done with covers in place and with careful tamping so as to avoid distortion of the enclosure. When installation is complete, the cover of the enclosure shall not be lower than two inches above final grade and shall not be higher than four inches above final grade. Soil in the immediate vicinity shall be tamped and sloped away from the enclosure. At the OWNER's option, the soil shall be removed from the site or spread evenly over the surface of the ground to the satisfaction of the OWNER.

8.14 UTILITY SAFETY SIGNS

- 8.14.1 A "Warning" sign shall be installed on the outside of each piece of equipment and a "Danger" sign on the inside of each piece of equipment. The signage shall be compliant with ANSI Z535.2, Environmental Safety Signs.

8.15 GROUNDING

- 8.15.1 All neutral conductors, grounding electrodes, and groundable parts of equipment shall be interconnected. A minimum of one copper-clad ground rod with a minimum length of eight feet shall be installed at all equipment locations, vaults, and taps.
- 8.15.2 All pad-mount equipment enclosures, including transformers, shall be grounded in such a manner that two separate grounding paths exist between enclosure and the grounding rod(s).

8.16 CABLE LOCATION MARKERS

- 8.16.1 Permanent cable locations markers shall be installed as shown on the staking sheets, but in no case shall they be more than 500 feet apart or 500 feet from a piece of electrical equipment.

8.17 CABLE ACCEPTANCE TESTS

- 8.17.1 Continuity: After installation of the cable and prior to the high potential test specified below, authorized personnel shall perform a simple continuity test on the system. This can easily be accomplished by grounding the conductor at the source and checking for continuity at the end of each tap with an ohmmeter.
- 8.17.2 Megger: After successful continuity tests, authorized personnel shall perform megger tests (either 1kV or 5kV) on each length of cable, with terminations in place, but disconnected from the system. The values for each phase shall be recorded and shall be within 10% of each other.